

sapa:

buildingsystem

ARCHITECTURAL ALUMINIUM SOLUTIONS



Ground Floor Treatments

Technical Data Sheet

Thermally Broken Commercial Entrance Door & Framing

Non-thermally Broken Commercial Entrance Door & Framing

Sapa Building System

Ground Floor Treatment

Contents

| | |
|-------|--|
| 3 | Support Services |
| | Stormframe ST Thermally Broken Commercial Entrance Door & Framing |
| 4 | Design Features |
| 5 | Performance Data |
| 6 | Thermal Performance Graphs |
| 10 | Profile Identification & Inertia Values |
| | General Arrangements: |
| 12 | Centre Pivot Door - Horizontal Section - Standard Stiles |
| 13 | Centre Pivot Door - Vertical Section |
| 14 | Centre Pivot Door - Horizontal Section - Wide Stiles |
| 15 | Rebated Door - Horizontal Section |
| 16 | Rebated Door - Vertical Section |
| 17 | Deep Bottom Rail Adaptor |
| 18 | Alternative Ramped, Drainage and Zero Threshold Arrangement |
| 19 | Coupling Head to Window Wall Cill |
| 19 | Coupling Jamb to Window Wall Jamb |
| 20 | Coupling Jamb to Elegance 52 Curtain Wall |
| 20 | Coupling Head to Elegance 52 Curtain Wall |
| 21 | Door Stile to Mullion |
| 21 | Mullion & Jamb |
| 22 | Transom Over Door |
| 22 | Head - Transom - Cill |
| | 202 Non Thermally Broken Commercial Entrance Door & Framing |
| 24 | Design Features |
| 25 | Performance Data |
| 26 | Profile Identification & Inertia Values |
| | General Arrangements: |
| 28-29 | Centre Pivot Door |
| 30-31 | Standard Stile Options |
| 32-35 | Standard Meeting Stile Options |
| 36 | Standard Top Rail Options |
| 37 | Standard Bottom Rail Options |
| 38 | Standard Lay Bar and Mid Rail Options |
| 39 | Standard Door Head/Transom Options - centre pivot |
| 40 | Standard Door Head/Transom Options - rebate |
| 41 | Standard Door Transom Options |
| 42 | Standard Door Cill Options - centre pivot |
| 43 | Standard Door Cill Options - rebate |
| 44 | Standard Door Jamb Options - centre pivot |
| 45 | Standard Door Jamb Options - rebate |
| 46 | Standard Fixed Frame Options - head |
| 47 | Standard Fixed Frame Options - transom |
| 48 | Standard Fixed Frame Options - mid rail |
| 49-50 | Standard Fixed Frame Options - cill and sub cill |
| 51 | Standard Fixed Frame Options - jambs |
| 52 | Standard Fixed Frame Options - mullion |
| 53 | Standard Fixed Frame Options - corner post |
| 54 | Standard Fixed Frame Options - 75mm framing |

Support

Support services

- Our field based Project Consultants, working with our in-house Contracts Design and Administration team, provide UK specifiers with specialist advice concerning the correct application of products, giving guidance on Building Regulations, British Standards and other issues such as product specifications, usage, maintenance and safety. Complementary to this, our Product Support Department has an invaluable reservoir of experience on every aspect of our product range.
- We also appreciate that the specification process is influenced by client demands to obtain best value, and to that end, we can participate in site visits, design meetings and budgetary planning. Design stages can be formalised through written specification documents (which can be supplied in either an NBS format, or your own specification layout) and supported by samples, literature and drawings for consultation or planning issues.
- Taking this partnership approach through the whole project allows on-site monitoring of manufacturing and installation ensuring the specifier always has professional support from a worldwide group. Drawing on one of the largest fabricator and installer networks in the UK, we can provide details of specialist contractors who will quote or tender competitively for any type of contract.
- For specification assistance or details of fabricators & installers, please call our Marketing Department on 01684 853500.

■ Sapa Group

Sapa Building Systems Limited is a member of the worldwide Sapa Group. We develop and market high value-added profiles in aluminium and are the leading independent producer of aluminium profiles in the world, with customers in Europe, North America and Asia. In the UK, the Sapa Group has extensive multi-site extruding, re-melt, anodising and polyester powder coating facilities, offering total control and a fast and co-operative response.

Backed by the resources of the Group, Sapa Building Systems Limited offers architects and specifiers a wide range of innovative aluminium systems for curtain walling, doors, windows and specialist applications. With a wealth of European knowledge and experience our company incorporates the highly respected Glostal, Monarch and RC System brands that have satisfied the demands of specifiers for over four decades. Our company systems have been approved under BS EN ISO 9001:2000 and we have been recognised as an Investor in People for over three years.



FM01154

ST Thermally Broken Commercial Entrance Door & Framing

- **Flexible design:** The Sapa Stormframe range of commercial doors and framing includes: a thermally broken door; a non-thermally broken door and non-thermally broken framing.

Together the Stormframe range offers specifiers a choice of systems to suit the specific demands of their clients.

Choice of pivot (with anti-finger trap stile option) or rebated doors can be installed with a BS8300 bottom rail adaptor, Part M compliant drained threshold and upto 32mm glazing. Designed to accept a wide range of industry standard hardware including Dorma, Axim and Adams Rite.

- **Superior thermal performance:** The Stormframe ST Door offers high levels of both thermal insulation achieving a U value of 2.2 W/m²K. This low U value can help building designers to achieve their Target Emissions Rate (TER) by being offset against the allowable U value of 6.0 W/m²K for high traffic doors when calculating the Building Emissions Rate (BER).

The ST Door can be coupled to Dualframe framing and Elegance 52 curtain walling to provide a complete solution for building facades requiring high levels of thermal performance.

- **Dual colour capability:** The Stormframe ST door and Dualframe systems can have differing finishes internally and externally.
- **Integrated design:** The Stormframe suite consists of a range of profiles that can be integrated with other products from the extensive range of systems including curtain walling.
- **Unique polyamide thermal barrier:** The ST door and framing provides thermal insulation via a high performance polyamide thermal barrier.
- **Ease of maintenance:** The design of the Stormframe system ensures that cleaning and other maintenance can be carried out easily.

■ Product

Stormframe ST thermally broken commercial entrance door and framing.

■ Design Variants

Can be constructed to form single or double doors to be inserted directly into masonry, side frames or curtain walling.

■ Compatibility

Can also be integrated with other products from the Sapa range including Dualframe and Elegance 52 curtain walling.

■ Application

Suitable for installation in new build or replacement projects in commercial or public buildings.

■ Finishes

A wide range of polyester powder coat finishes is available to BS EN 12206:1 2004. Anodised finishes are to BS 3987 Grade AA25 etch silver with a range of special anodised finishes on application.

For more details, or to talk to a Project Consultant, contact the Marketing Department on 01684 853500.

Stormframe ST Thermally Broken Commercial Entrance Door & Framing

Composition and Manufacture

Aluminium profiles are extruded from aluminium alloy 6060 T6 complying with the recommendations of BS EN 755-9:2001.

Weathersealing is a combination of polypropylene backed woven pile and extruded synthetic rubber seals held in undercut grooves extruded in the aluminium profiles.

The thermal barrier section within the ST Door variation is achieved using two separate aluminium extrusions and two polyamide extrusions mechanically jointed to form a single compound profile.

Frame members are square cut for jointing with self tapping screws fixing into screw splines extruded in the aluminium profiles. Door leaf profiles are square cut and assembled with extruded aluminium brackets and clamp plates then fixed with M8 socket cap head machine screws. All joints are sealed against water entry during fabrication (see weather performance).

Weather Performance

There are no recognised performance standards for air and water leakage through commercial doors. However the **ST Door** has been tested in line with BS 6375: Part 1:2004 and has achieved the highest classification for doors when manufactured, installed and glazed strictly to the details outlined in the Sapa Product Manual.

Water Tightness Class 3A (100 Pascals)

Air Permeability Class 2 (300 Pascals)

Gust Class A3 (1200 Pascals)

Note - Adams Rite 4022 head and cill bolts to top and bottom of door must be used to obtain this classification.

In keeping with industry recommendations, it is advisable to give special consideration to doors on exposed sites. High wind pressures can cause inadvertent opening of pivoted doors and consequent draughts and water penetration. It may be advisable under such circumstances to provide protection by means of a porch or lobby.

All joints must be coated with Tremco small joint sealant or similar in order to effectively seal the frame and leaf assembly from water penetration.

Authority

BS 6262: Code of practice for glazing for buildings.

BS EN 755-9: Aluminium and aluminium alloys. Extruded rod/bar, tube and profiles.

Profiles, tolerances on dimension and form. BS 3987: Specification for anodic oxide coatings on wrought aluminium for external architectural applications.

BS EN 12206:1 2004: Specification for powder organic coatings for application and stoving to aluminium alloy extrusions, sheet and perforated sections for external architectural purposes.

Sizes

Door leaf maximum sizes will be determined by a combination of site exposure conditions and hardware specification.

For rebated doors, the overall leaf weight should not exceed 120 Kg for a two-hinge installation.

For centre pivot doors, suitable strengths closers must be fitted according to the width and area of the door leaf.

Maximum door leaf weight = 90 Kg.

Minimum door width is 910mm for Adams Rite exit device when panic bar is fitted.

Maximum opening size for pivot and rebate doors leaves are 2150mm high x 1175mm wide (1050mm wide for concealed closers).

For doors subject to Part M of the Building Regulations, and/or BS8300:2001, consideration should be given to the requirements within those documents for minimum opening widths and opening/closing forces when specifying door dimensions and hardware.

Hardware and Security

The standard fittings provided for these doors are:

Dorma RTS85 concealed overhead door closers for pivoted doors and Dorma pivot hinges for rebated doors.

Adams Rite MS 2200 security lock with hook bolt and European standard profiles cylinders with optional Adams Rite 4022 head and cill bolt to top and bottom of door.

Aluminium tubular pull handles and pad handles.

Variations by way of special handles, pivot hinges, latch lock, master key systems, emergency exit devices (as shown in the Sapa Product Manual), automatic door operation, electronic security etc can all be incorporated into the system as required.

Glazing

Glass must conform to the requirements of BS6262 for thickness and type. Glass is set dry against synthetic rubber gaskets. Glass is supported on adjustable setting blocks. Glazing beads and gaskets will accommodate glass and/or panels of 28mm and 32mm nominal thickness.

Thermal Performance

The graphs on pages 6 TO 11 show U value performance figures for a typical ST Door with drained low threshold, standard top, mid and bottom rails with anti-finger trap hinge stiles. Figures for are standard aluminium edge spacers.

Site Work

Fabrication, installation and glazing service is available through a nationwide network of fabricators & installers. For details of suitable fabricators & installers, please contact our Marketing Department on 01684 853500.

U Value Graphs

Standard lock stile, Anti Finger Trap Hanging Stile

1.2 Centre Pane Without Midrail

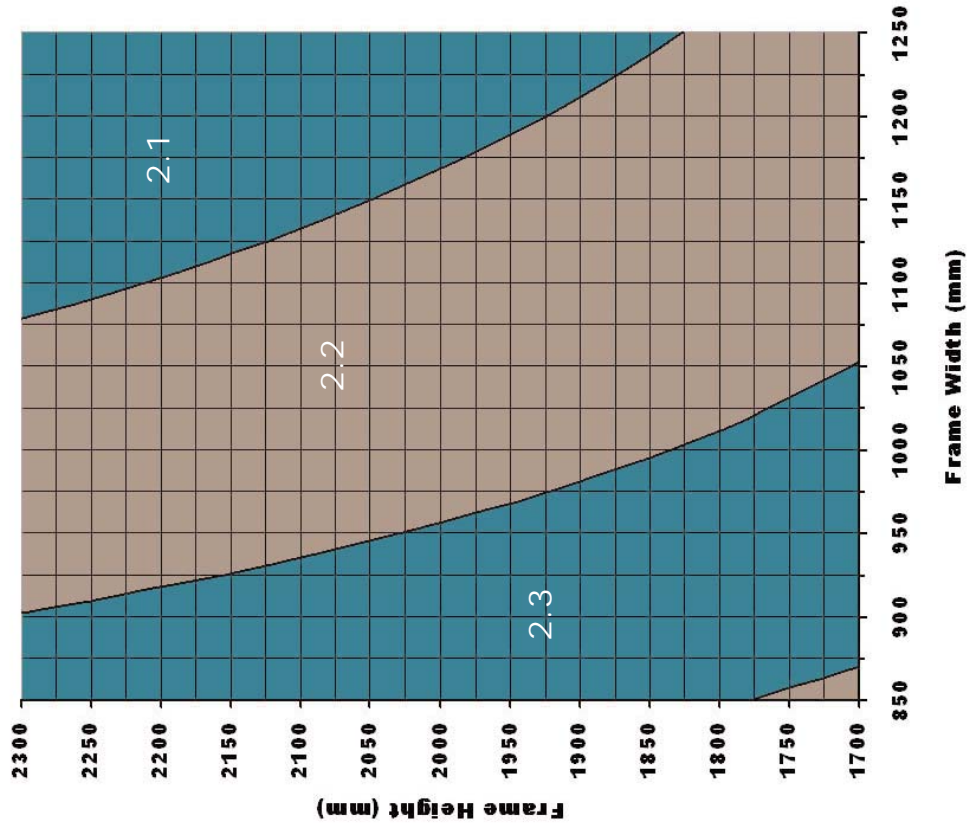

1.3 Centre Pane Without Midrail

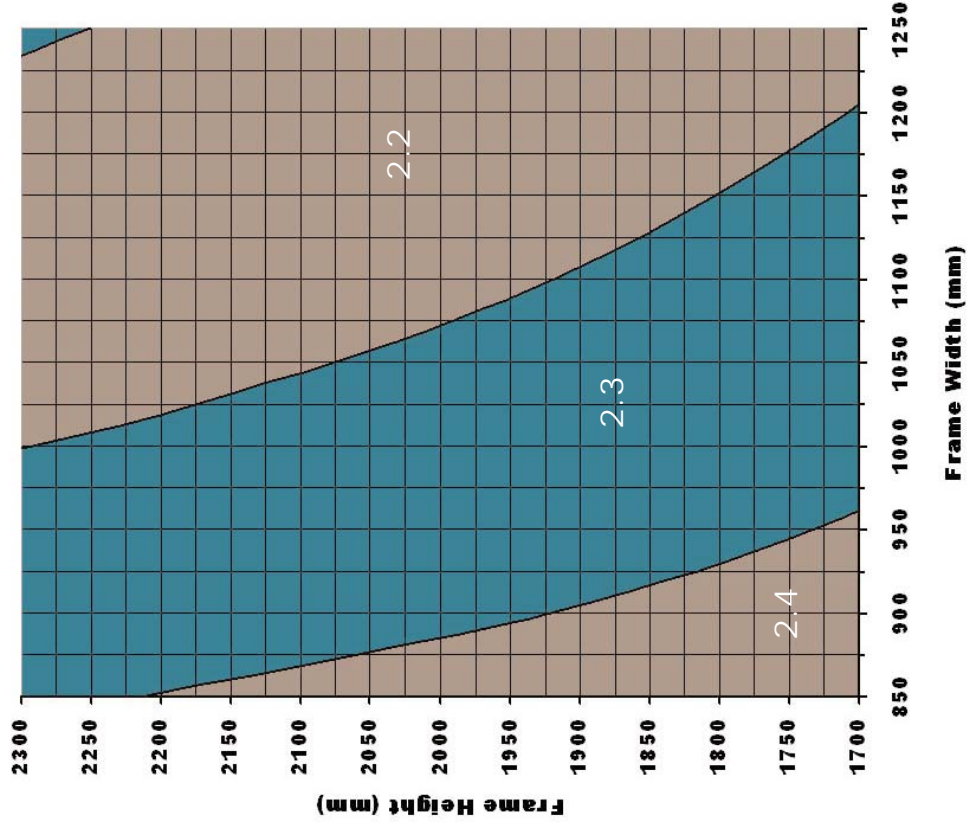

U Value Graphs
Standard lock stile, Anti Finger Trap Hanging Stile

1.4 Centre Pane Without Midrail

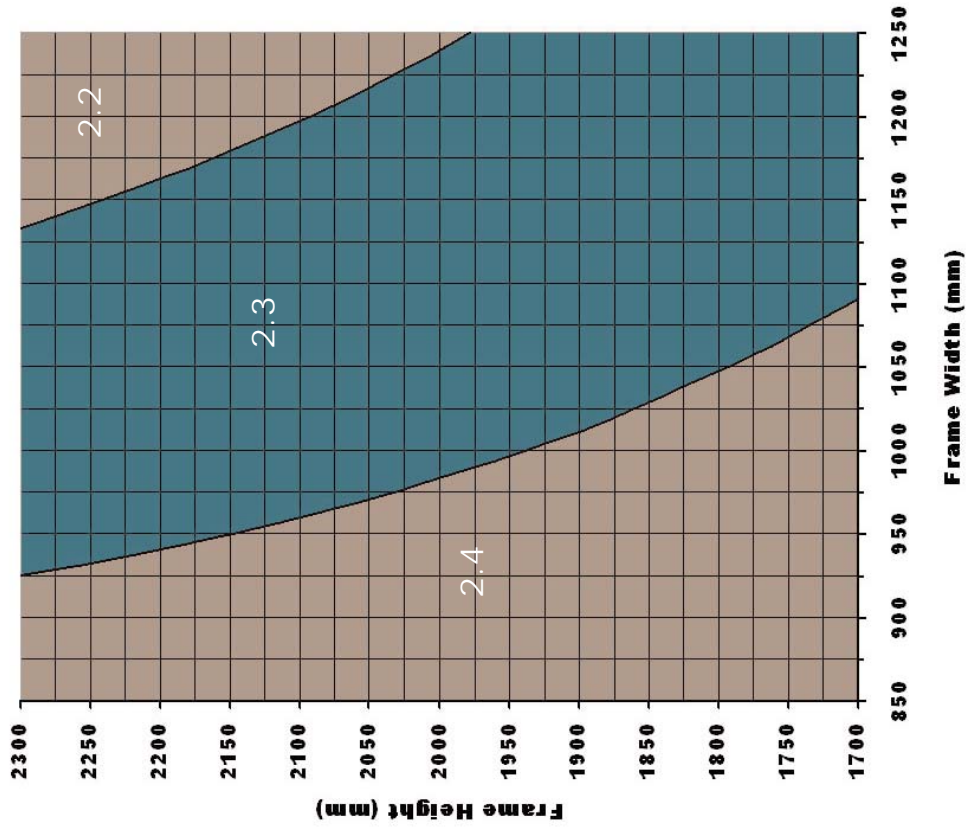

1.5 Centre Pane Without Midrail

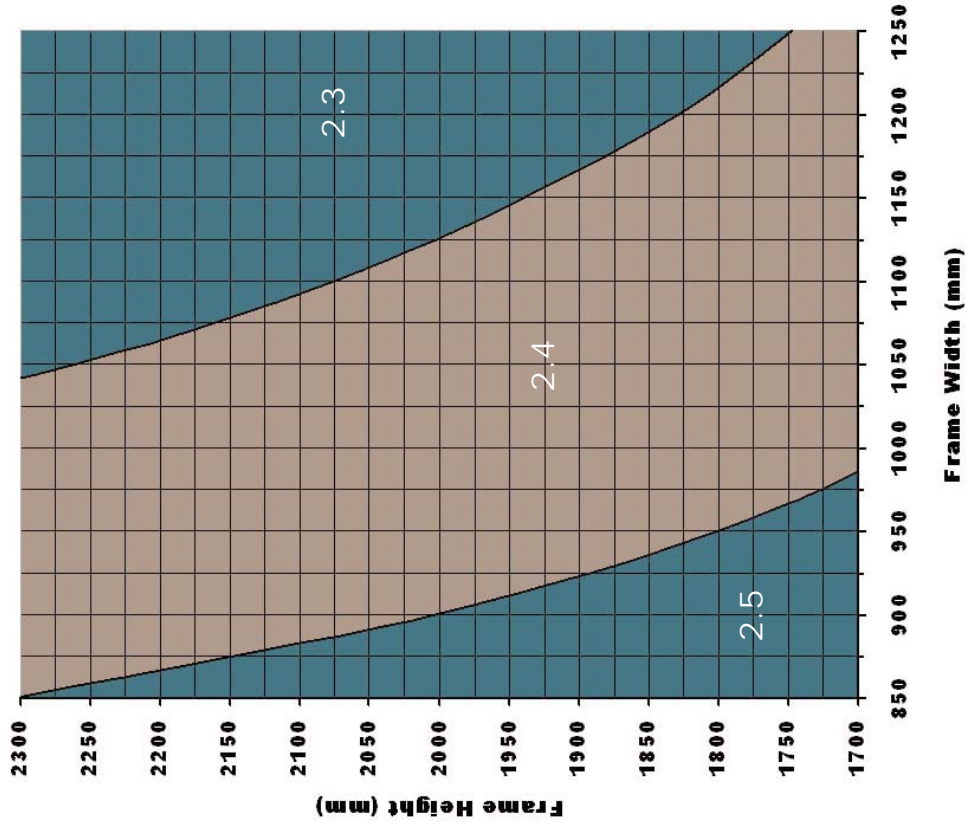

U Value Graphs Standard lock stile, Anti Finger Trap Hanging Stile

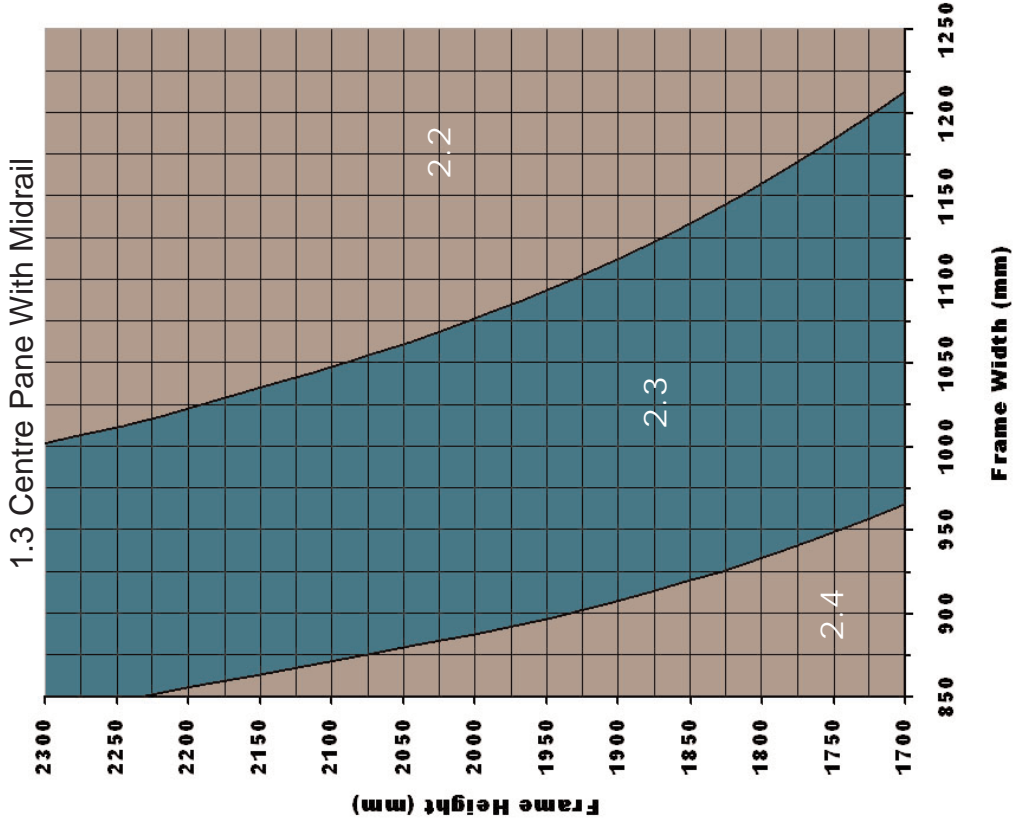
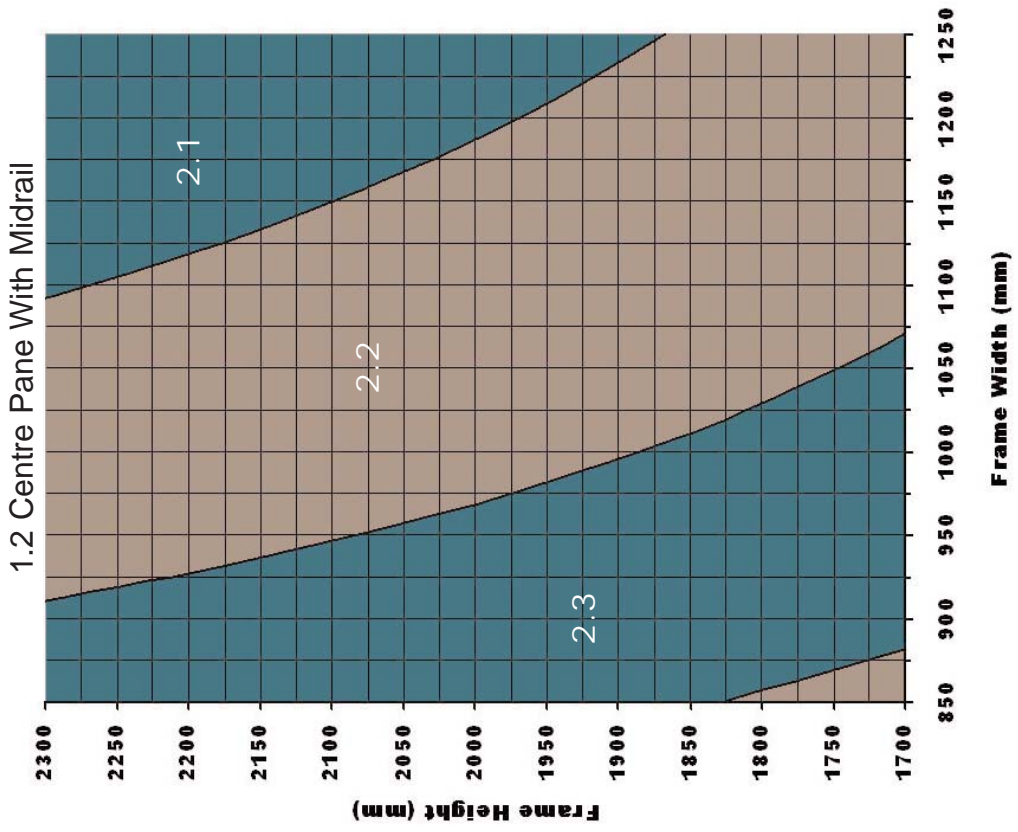

U Value Graphs
Standard lock stile, Anti Finger Trap Hanging Stile

1.4 Centre Pane With Midrail

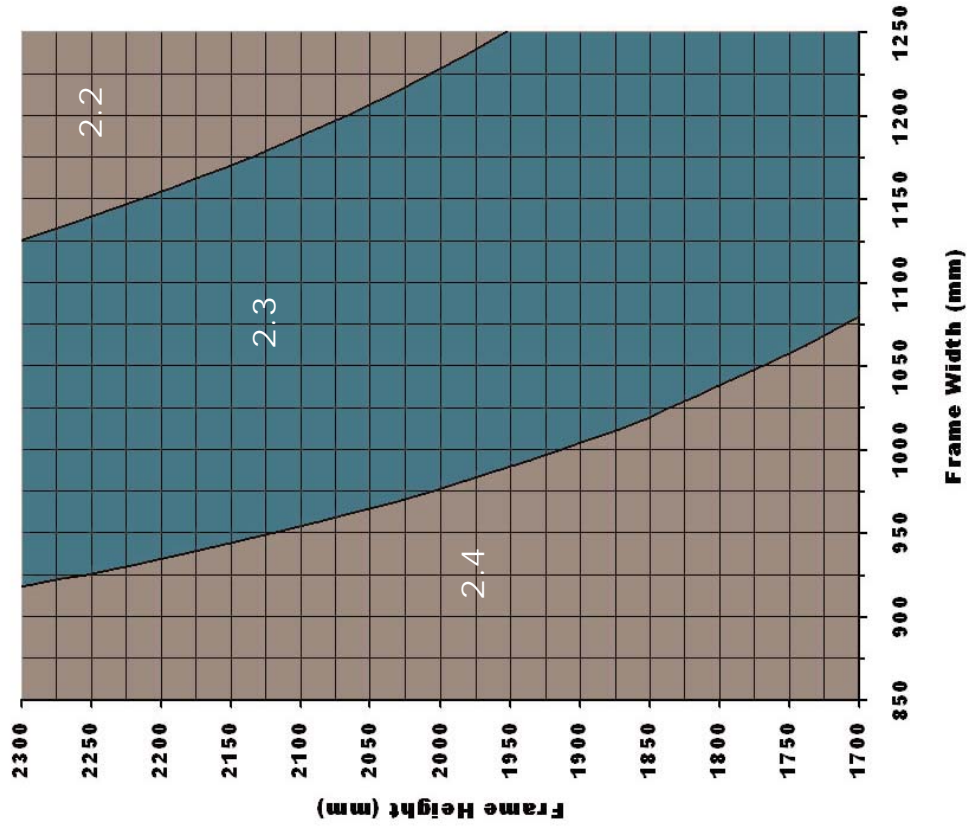



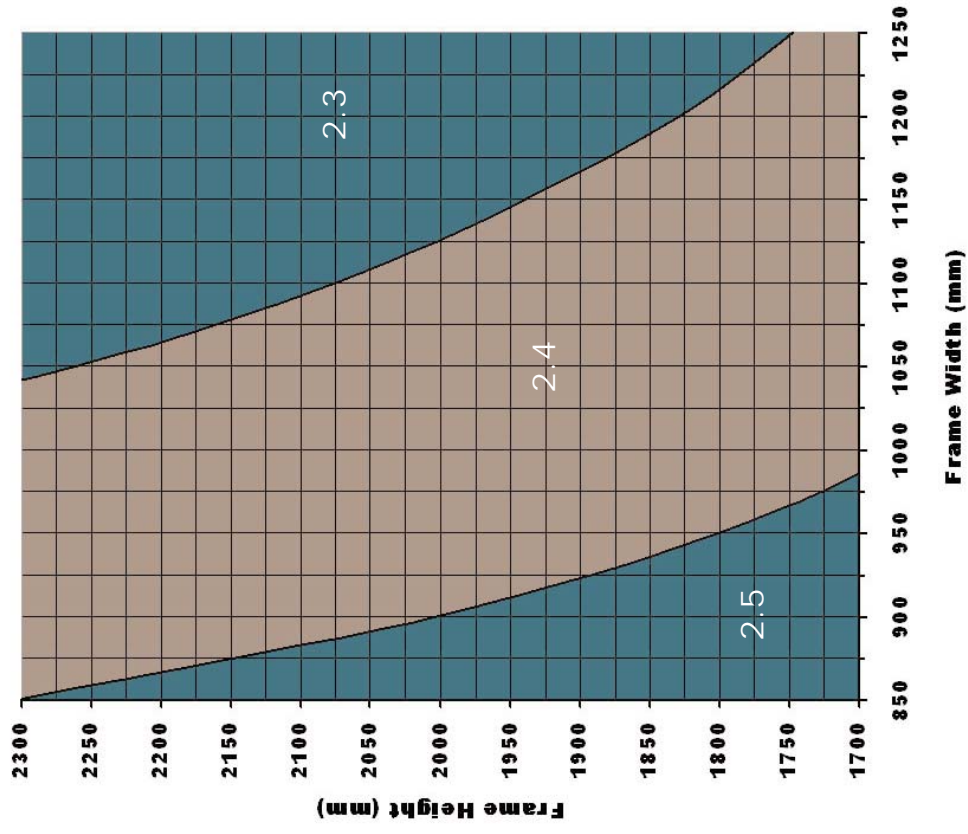







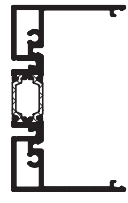

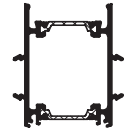



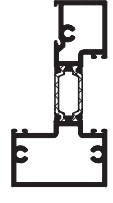

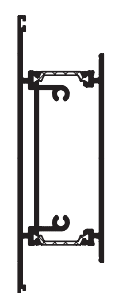



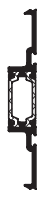

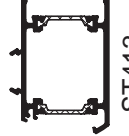



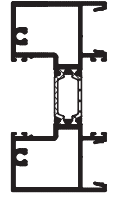

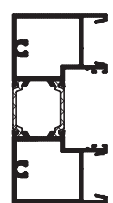
1.5 Centre Pane With Midrail

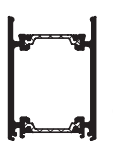

Stormframe ST Thermally Broken Commercial Entrance Door & Framing

PROFILE IDENTIFICATION & INERTIA VALUES

This page gives information on the inertia values of the integral mullions, transoms and coupling mullions. BS 6399 must be used to calculate the inertia value required.

| Profile | Inertia (mm ⁴) | Profile | Inertia (mm ⁴) |
|--|---|--|---|
|  ST405 |  572,255 |  ST410 |  133,842 |
| |  120,283 | |  123,646 |
|  ST406 |  478,450 |  ST412 |  1,042,561 |
| |  137,822 | |  215,291 |
|  ST407 |  122,564 |  ST413 |  148,103 |
| |  3,048 | |  121,224 |
|  ST408 |  530,300 |  ST414 |  523,447 |
| |  132,567 | |  137,318 |
|  ST409 |  134,047 |  ST419 |  641,556 |
| |  116,258 | |  184,354 |

Stormframe ST Thermally Broken Commercial Entrance Door & Framing

sapa:

GENERAL ARRANGEMENTS

| Elevation | Page |
|---|------|
| Centre Pivot Door - Horizontal Section - Standard Stiles | 12 |
| Centre Pivot Door - Vertical Section | 13 |
| Centre Pivot Door - Horizontal Section - Wide Stiles | 14 |
| Rebated Door - Horizontal Section | 15 |
| Rebated Door - Vertical Section | 16 |
| Deep Bottom Rail Adaptor | 17 |
| Alternative Ramped, Drainage and Zero Threshold Arrangement | 18 |
| Coupling Head to Window Wall Cill | 19 |
| Coupling Jamb to Window Wall Jamb | 19 |
| Coupling Jamb to Elegance 52 Curtain Wall | 20 |
| Coupling Head to Elegance 52 Curtain Wall | 20 |
| Door Stile to Mullion | 21 |
| Mullion & Jamb | 21 |
| Transom Over Door | 22 |
| Head - Transom - Cill | 22 |

These drawings illustrate a number of the available profile combinations. Other combinations are available please consult Sapa Building Systems for further details.

Stormframe ST Thermally Broken Commercial Entrance Door & Framing

GENERAL ARRANGEMENTS

Centre Pivot Door - Horizontal Section - Standard Stiles

NOTE - Where an anti finger trap stile is not required, ST409 can be used instead, as per lock stile shown.

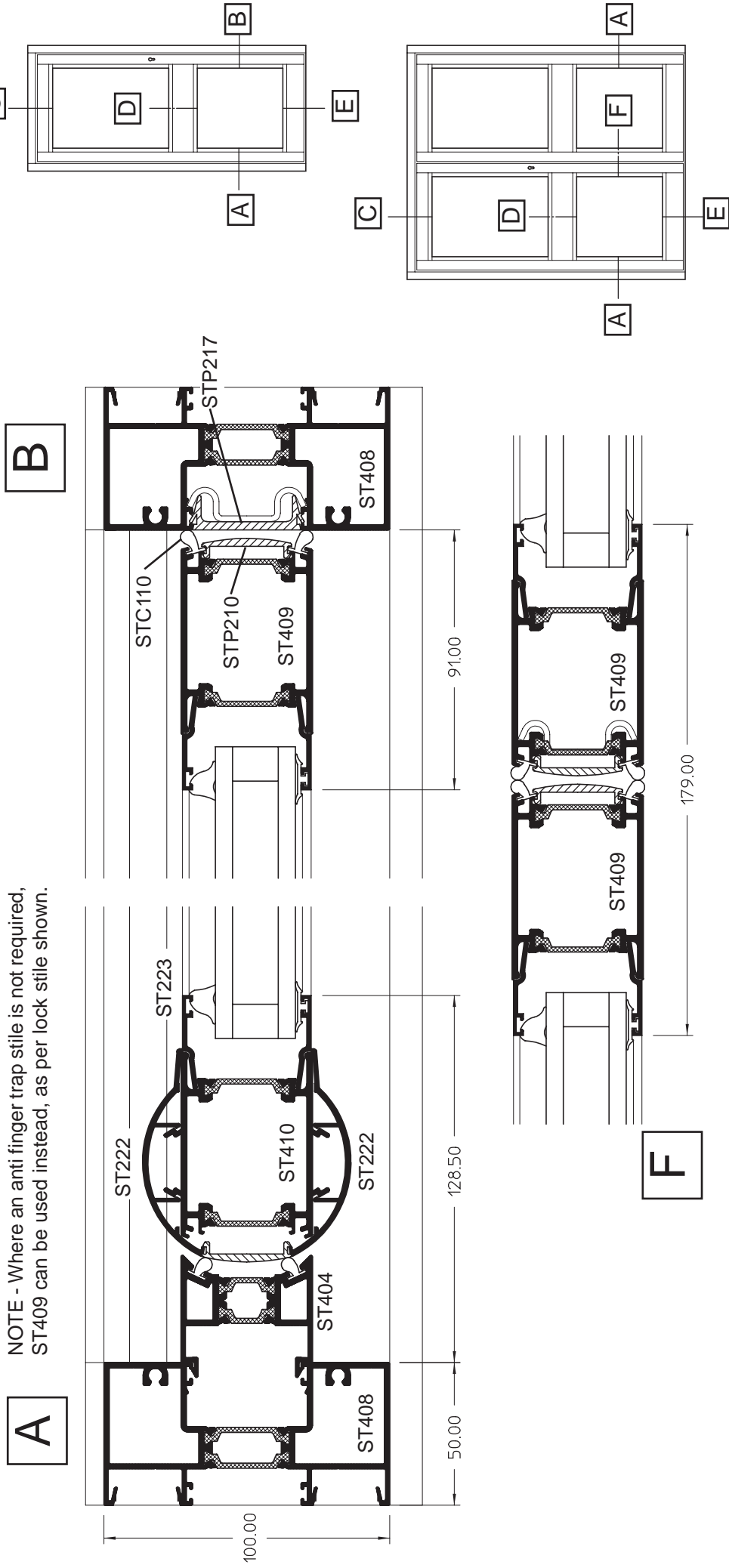

GENERAL ARRANGEMENTS

Centre Pivot Door - Vertical Section

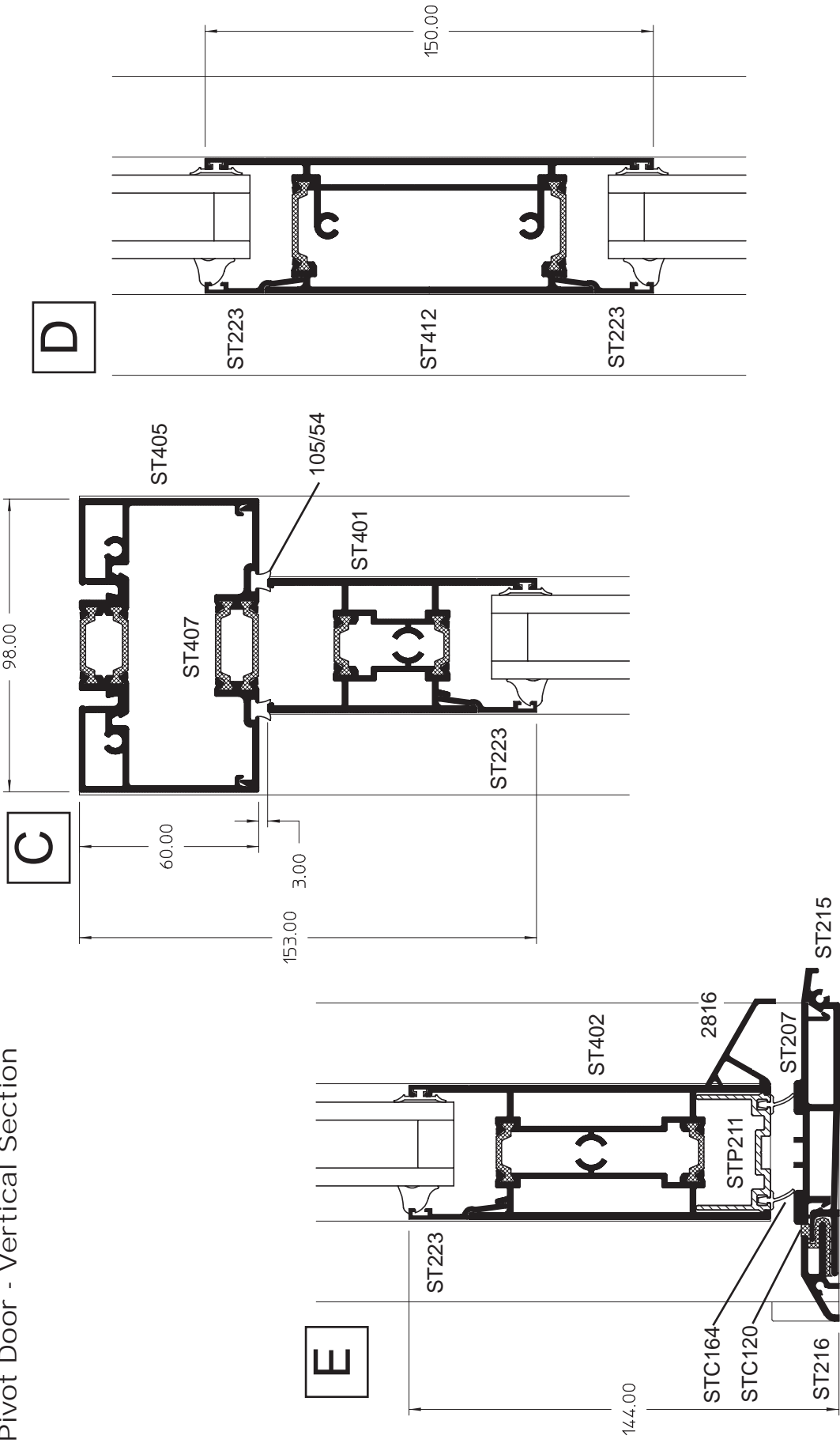

GENERAL ARRANGEMENTS

Centre Pivot Door - Horizontal Section - Wide Stiles

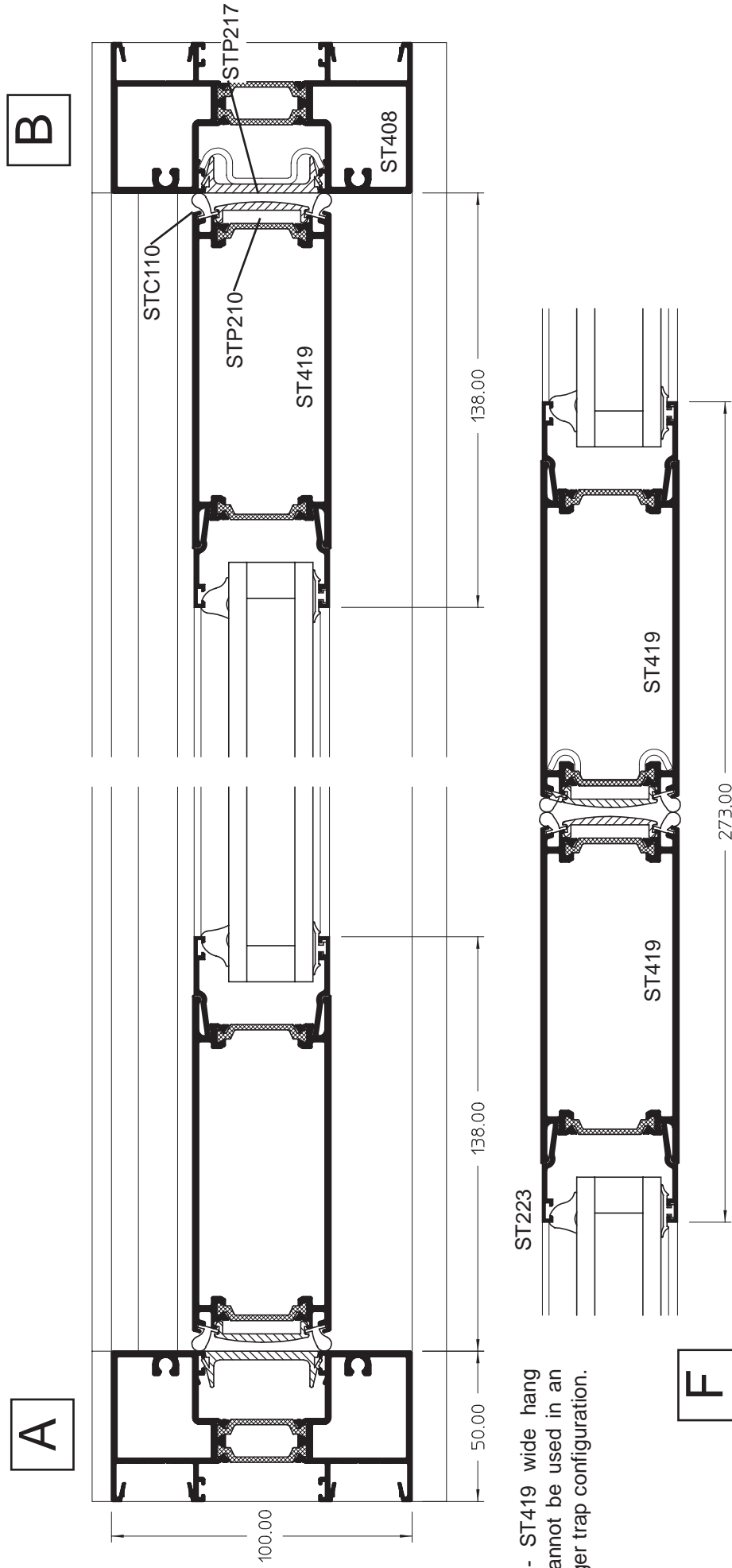

NOTE - ST419 wide hang stiles cannot be used in an anti finger trap configuration.

GENERAL ARRANGEMENTS

Rebated Door - Horizontal Section

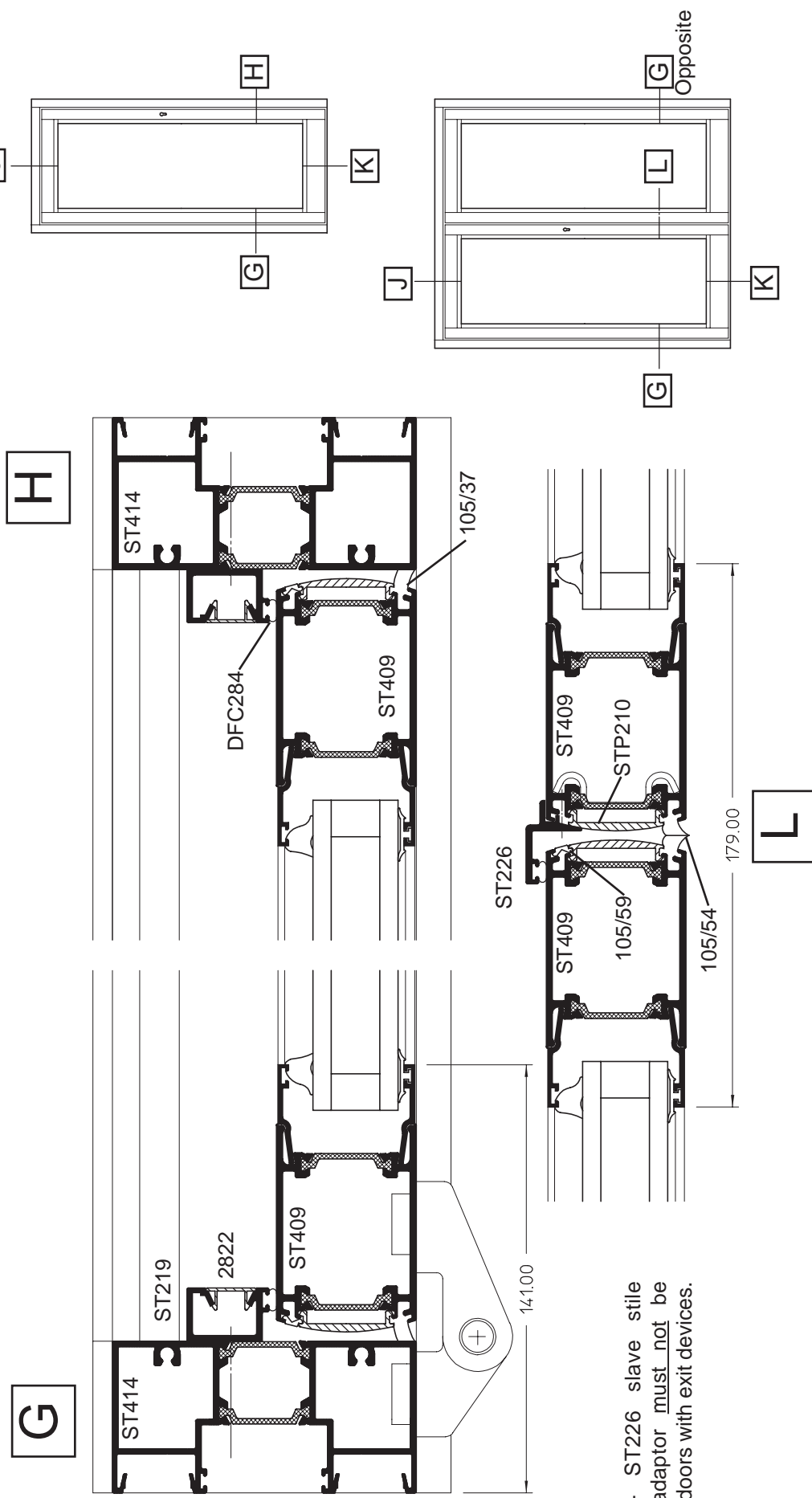

NOTE - ST226 slave stile rebate adaptor must not be used on doors with exit devices.

Stormframe ST Thermally Broken Commercial Entrance Door & Framing

GENERAL ARRANGEMENTS

Rebated Door - Vertical Section

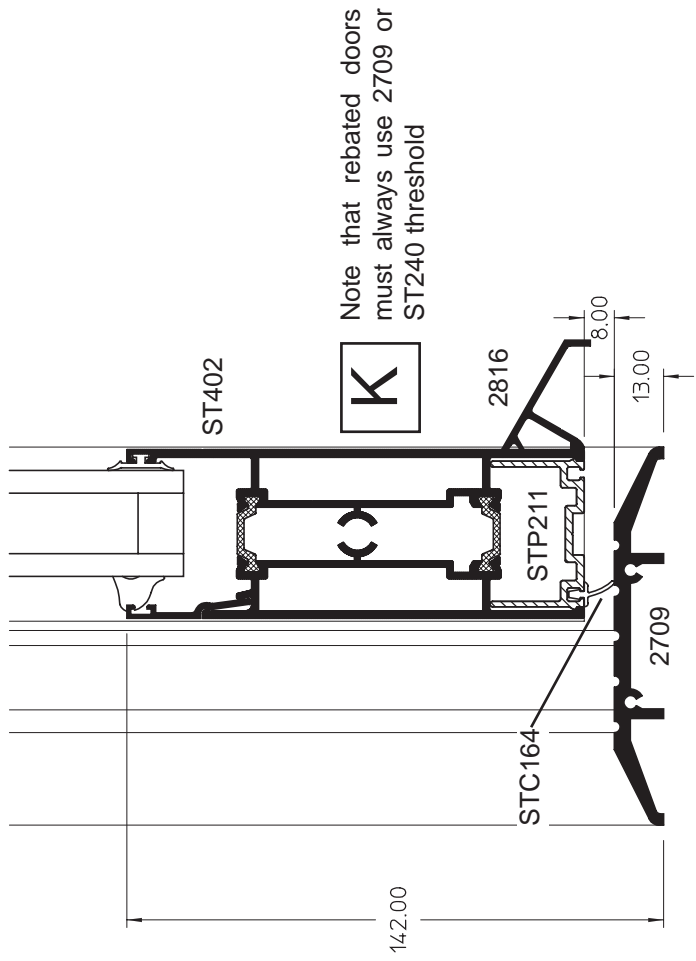
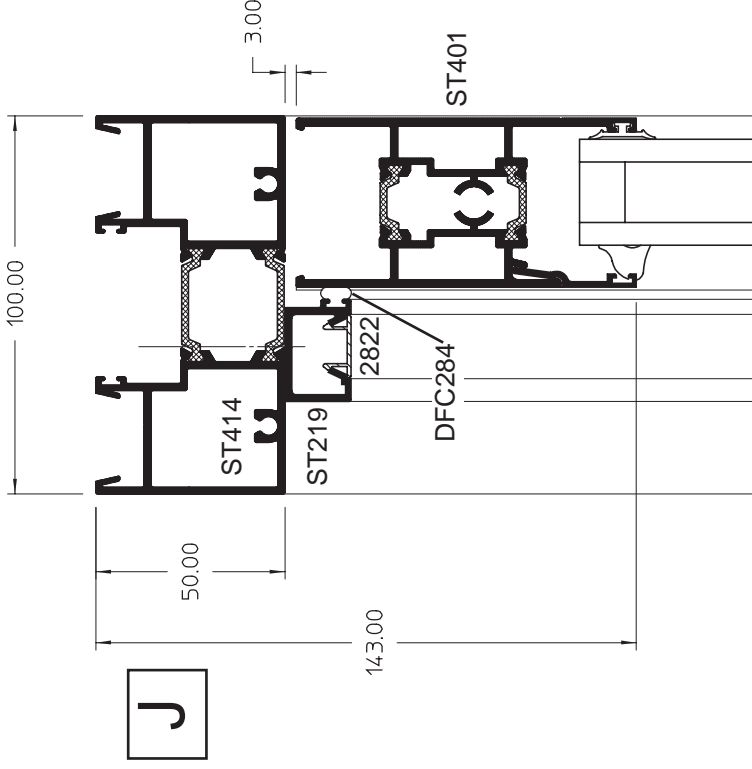

GENERAL ARRANGEMENTS

Deep Bottom Rail Adaptor

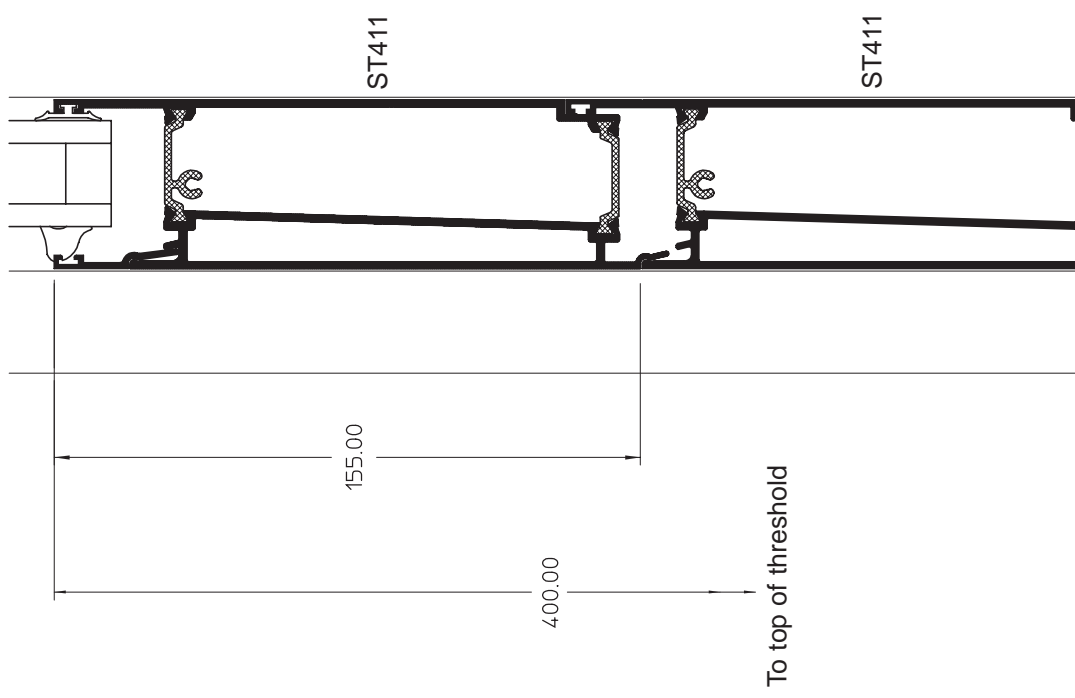
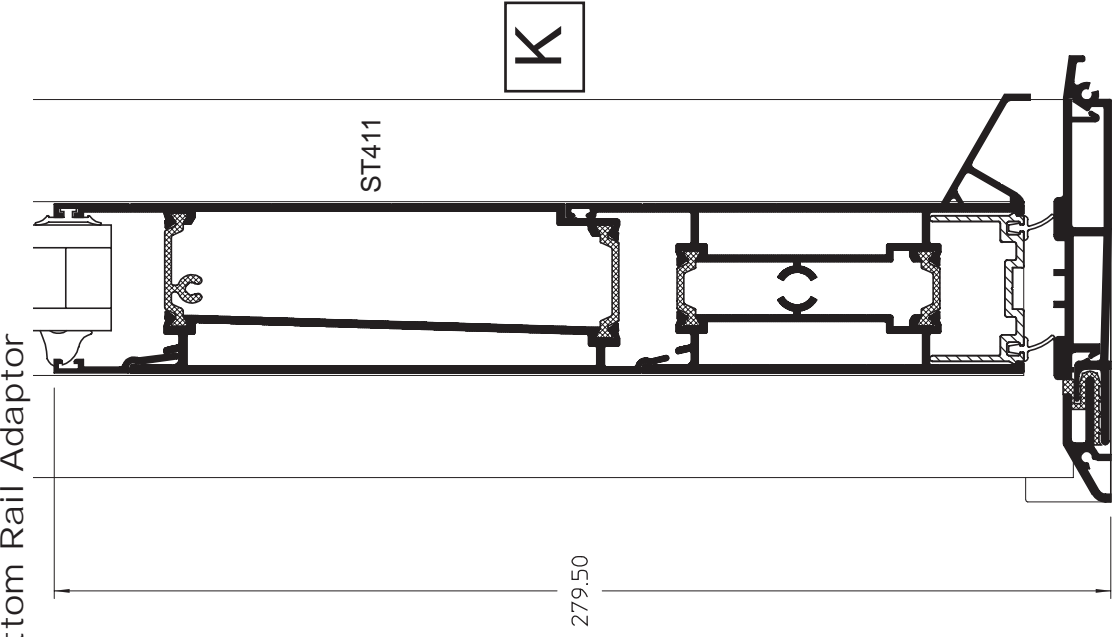

For compliance with BS 8300 regulations, fit two ST411 deep bottom rail adaptors to give the required 400mm dimension

Stormframe ST Thermally Broken Commercial Entrance Door & Framing

GENERAL ARRANGEMENTS

Alternative Ramped Threshold Arrangement

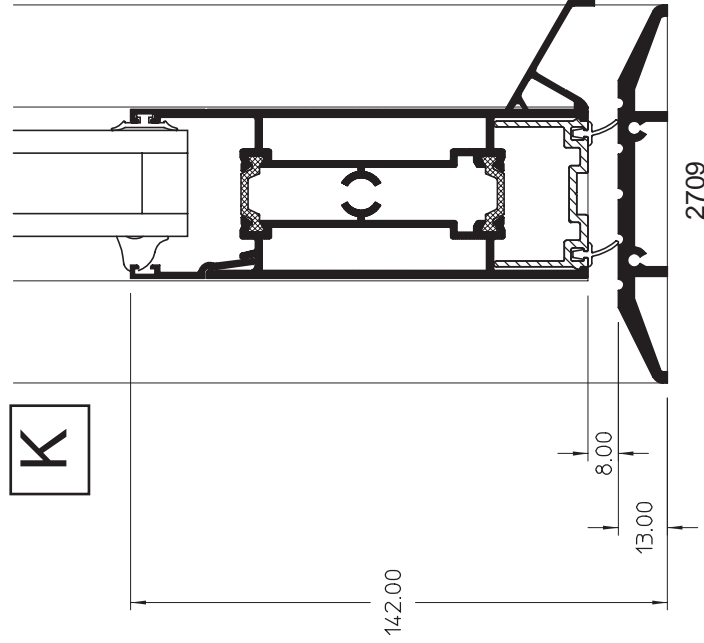

Alternative Drainage Threshold Arrangement

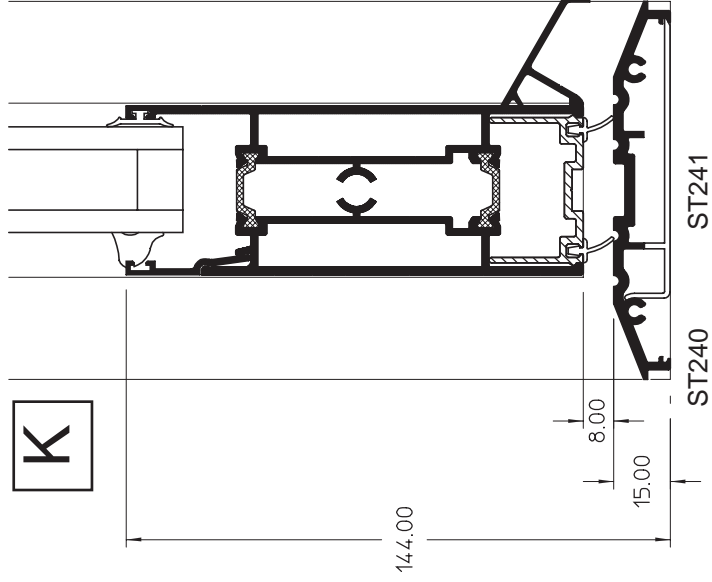

Alternative Zero Threshold Arrangement

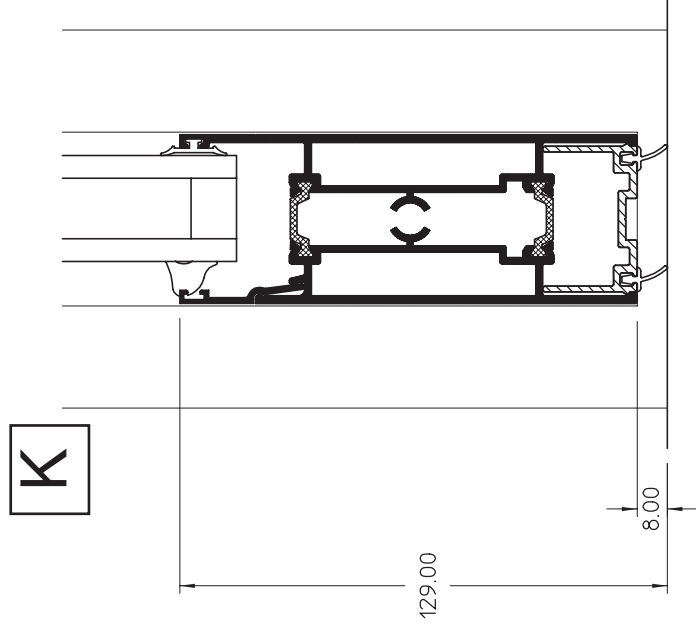

GENERAL ARRANGEMENTS

Coupling Head to Window Wall Cill

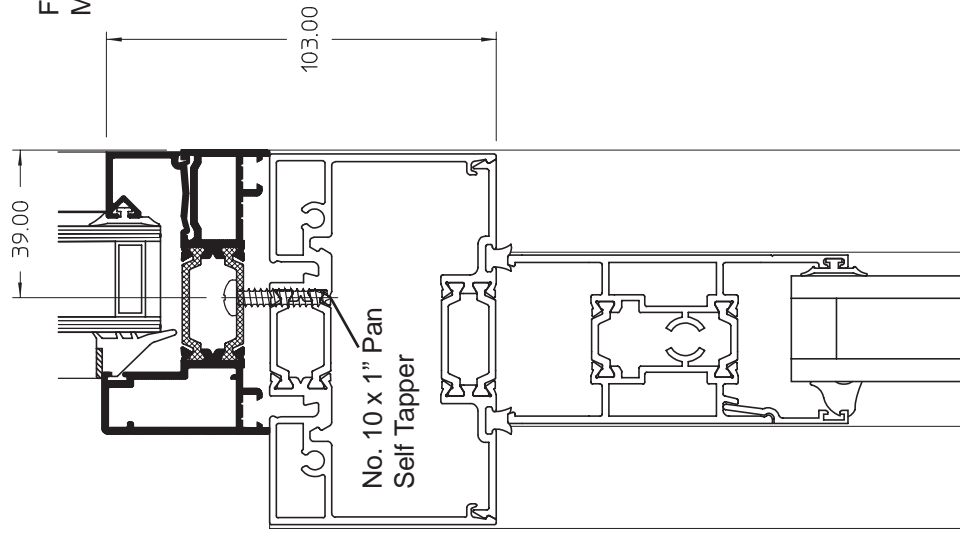

Coupling Jamb to Window Wall Jamb

For further details see Dualframe Window Wall Product Manual

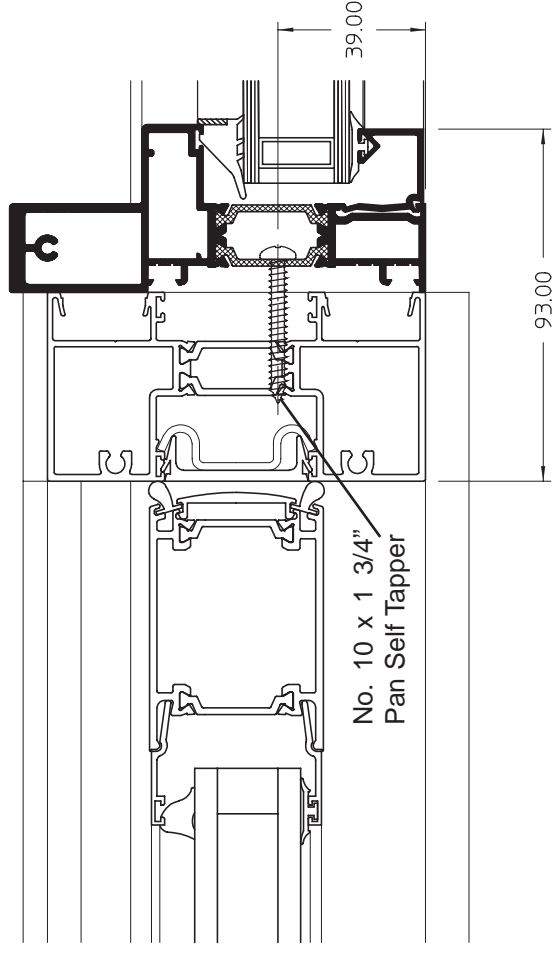

Coupling Jamb to Elegance 52 Curtain Wall

For further details see Elegance 52 Curtain Wall Product Manual

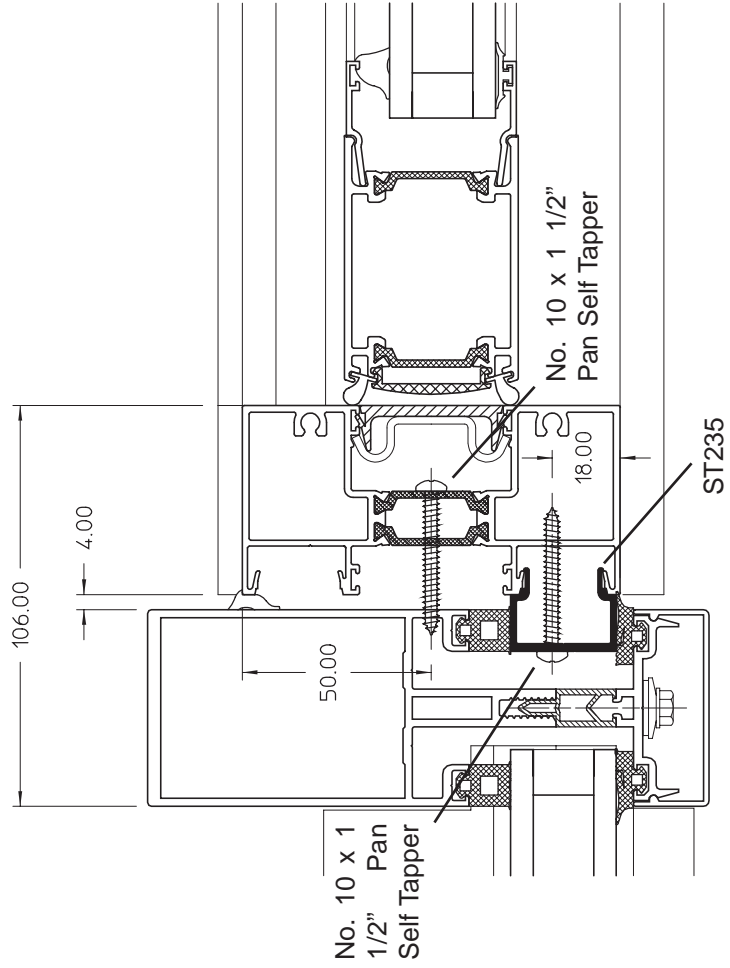

Coupling Head to Elegance 52 Curtain Wall

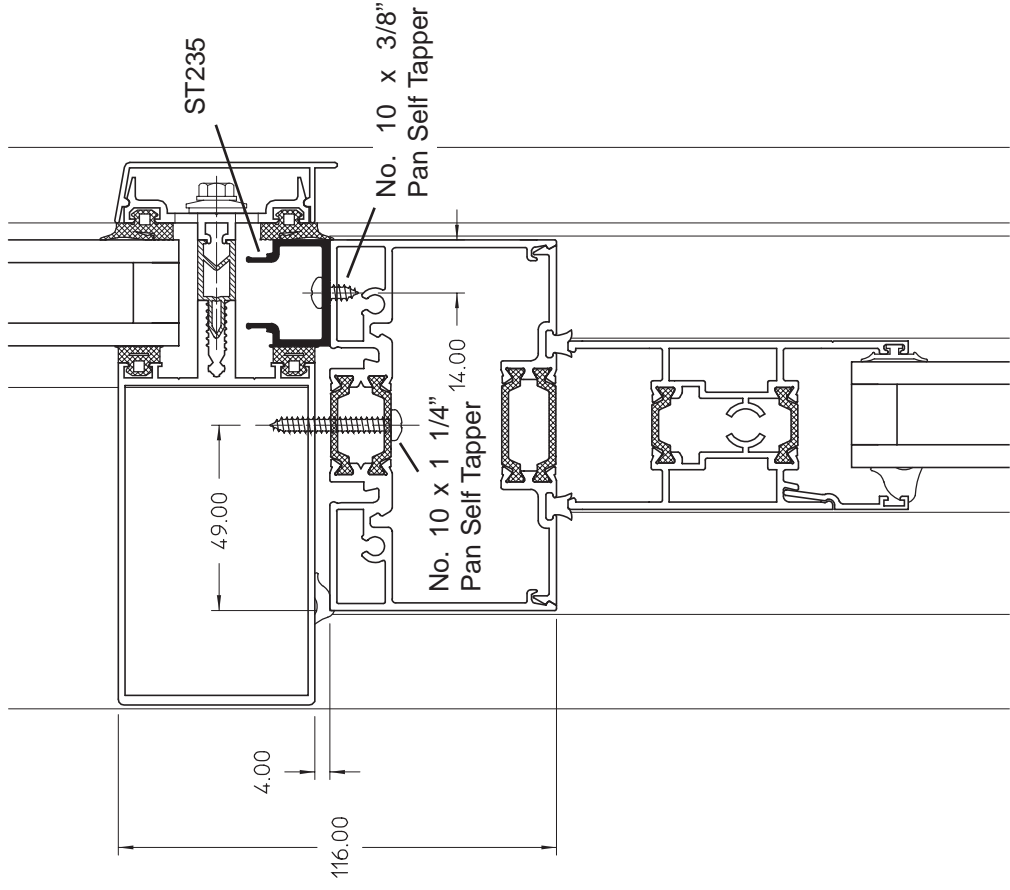

Stormframe ST Thermally Broken Commercial Entrance Door & Framing

GENERAL ARRANGEMENTS

Door Stile to Mullion

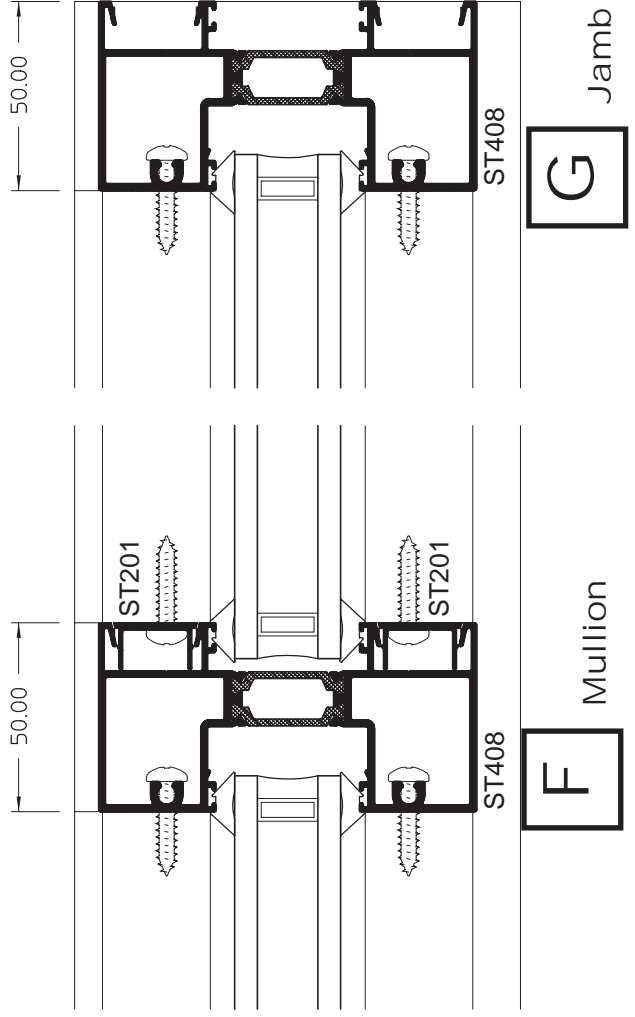
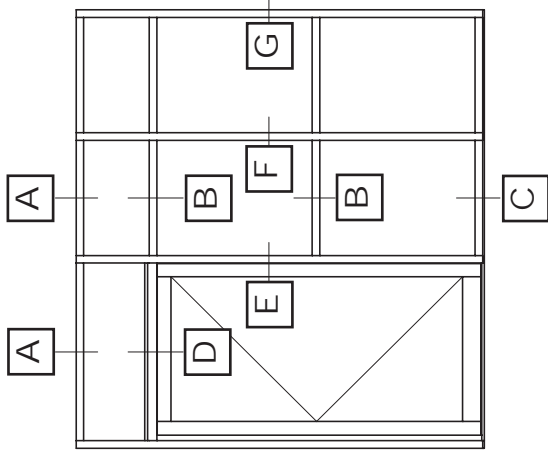
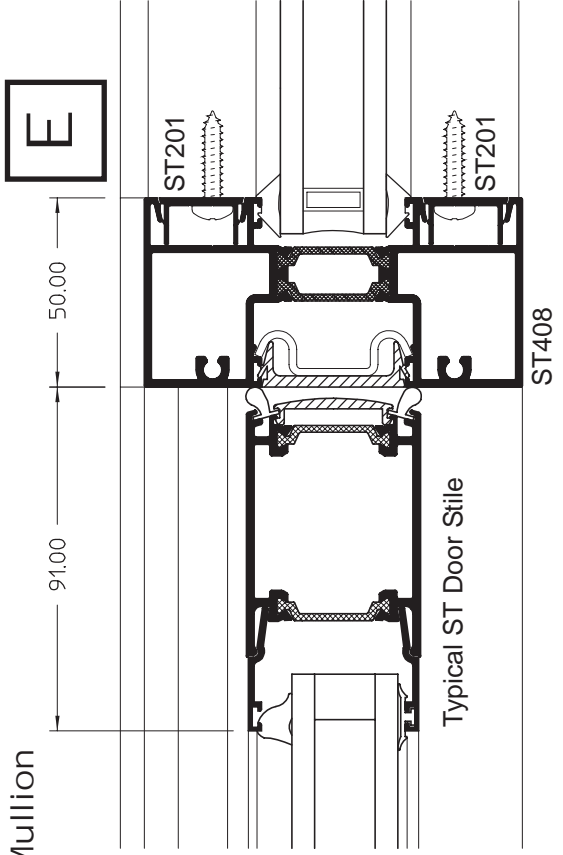

Stormframe ST Thermally Broken Commercial
Entrance Door & Framing

GENERAL ARRANGEMENTS

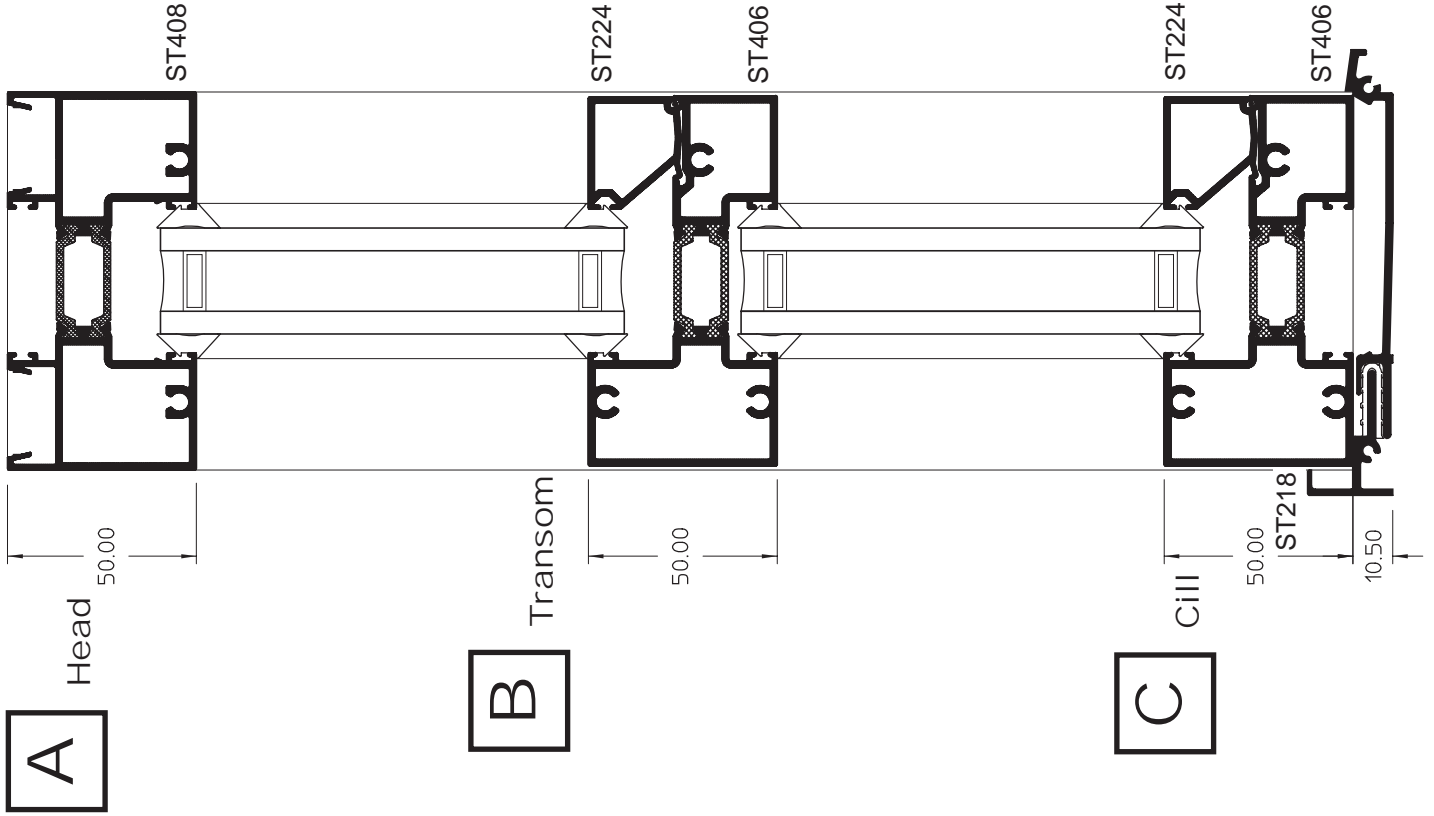

D Transom
Over Door

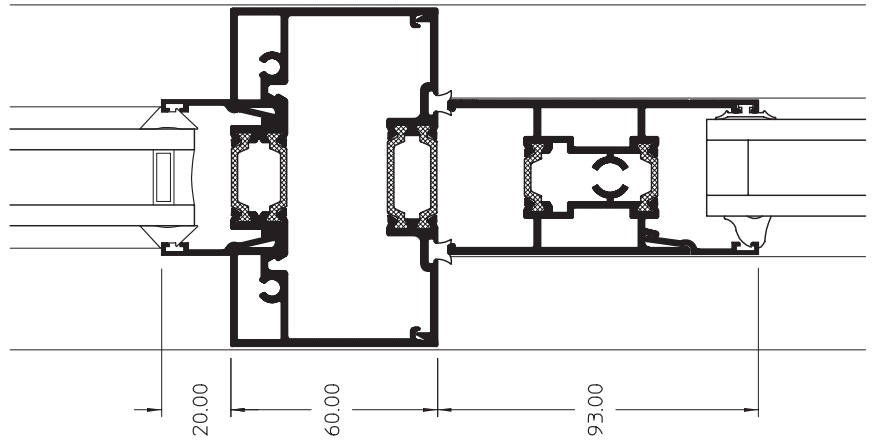

This page has been left intentionally blank

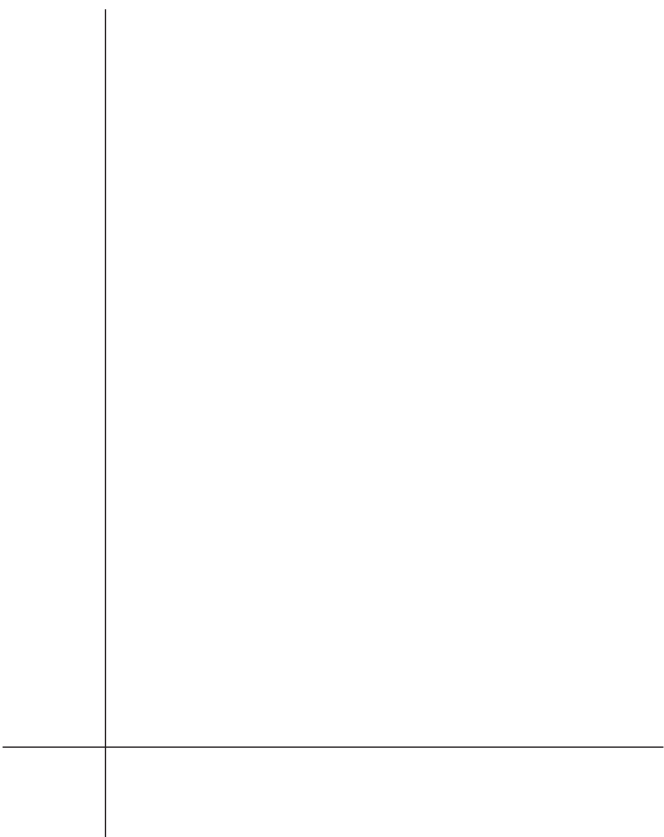

Design

Design Features

202 Non-thermally Broken Commercial Entrance Door & Framing

- **Flexible design:** The Sapa 202 Non-thermally Broken Commercial Entrance Door and Framing range includes a non-thermally broken door and non-thermally broken framing.
Together they offer specifiers a choice of configurations to suit the specific demands of their clients.
Choice of pivot (with anti-finger trap stile option) or rebated doors can be installed with a BS8300 bottom rail adaptor, Part M compliant drained threshold and upto 32mm glazing. Designed to accept a wide range of industry standard hardware including Dorma, Axim and Adams Rite.
- **Dual colour capability:** The 202 Non-thermally Broken Commercial Entrance Door and Framing and Dualframe systems can have differing finishes internally and externally.
- **Integrated design:** The 202 suite consists of a range of profiles that can be integrated with other products from the extensive range of systems including curtain walling.
- **Ease of maintenance:** The design of the 202 system ensures that cleaning and other maintenance can be carried out easily.

- **Product**
202 Non-thermally Broken Commercial Entrance Door and Framing.
- **Design Variants**
Can be constructed to form single or double doors to be inserted directly into masonry, side frames or curtain walling.
- **Compatibility**
Can also be integrated with other products from the Sapa range including Dualframe and Elegance 52 curtain walling.
- **Application**
Suitable for installation in new build or replacement projects in commercial or public buildings.
- **Finishes**
A wide range of polyester powder coat finishes is available to BS EN 12206:1 2004. Anodised finishes are to BS 3987 Grade AA25 etch silver with a range of special anodised finishes on application.

For more details, or to talk to a Project Consultant, contact the Marketing Department on 01684 853500.

202 Non-thermally Broken Commercial Entrance Door & Framing

Composition and Manufacture

Aluminium profiles are extruded from aluminium alloy 6060 T6 complying with the recommendations of BS EN 755-9:2001.

Weathersealing is a combination of polypropylene backed woven pile and extruded synthetic rubber seals held in undercut grooves extruded in the aluminium profiles.

Frame members are square cut for jointing with self tapping screws fixing into screw splines extruded in the aluminium profiles. Door leaf profiles are square cut and assembled with extruded aluminium brackets and clamp plates then fixed with M8 socket cap head machine screws. All joints are sealed against water entry during fabrication (see weather performance).

Weather Performance

There are no recognised performance standards for air and water leakage through commercial doors. Where certified weather performance is a requirement we recommend you consider the Sapa ST Thermally Broken Commercial Door and Framing system which has been tested in line with BS 6375: Part 1:2004.

In keeping with industry recommendations, it is advisable to give special consideration to doors on exposed sites. High wind pressures can cause inadvertent opening of pivoted doors and consequent draughts and water penetration. It may be advisable under such circumstances to provide protection by means of a porch or lobby.

All joints must be coated with Tremco small joint sealant or similar in order to effectively seal the frame and leaf assembly from water penetration.

Authority

BS 6262: Code of practice for glazing for buildings.

BS EN 755-9: Aluminium and aluminium alloys. Extruded rod/bar, tube and profiles. Profiles, tolerances on dimension and form. BS 3987: Specification for anodic oxide coatings on wrought aluminium for external architectural applications.

BS EN 12206:1 2004: Specification for powder organic coatings for application and stoving to aluminium alloy extrusions, sheet and perforated sections for external architectural purposes.

Hardware and Security

The standard fittings provided for these doors are:

Dorma RTS85 concealed overhead door closers for pivoted doors and Dorma pivot hinges for rebated doors.

Adams Rite MS 2200 security lock with hook bolt and European standard profiles cylinders with optional Adams Rite 4022 head and cill bolt to top and bottom of door.

Aluminium tubular pull handles and pad handles.

Variations by way of special handles, pivot hinges, latch lock, master key systems, emergency exit devices (as shown in the Sapa Product Manual), automatic door operation, electronic security etc can all be incorporated into the system as required.

Glazing

Glass must conform to the requirements of BS6262 for thickness and type. Glass is set dry against synthetic rubber gaskets. Glass is supported on adjustable setting blocks. Glazing beads and gaskets will accommodate glass and/or panels of 28mm and 32mm nominal thickness.

Site Work

Fabrication, installation and glazing service is available through a nationwide network of fabricators & installers. For details of suitable fabricators & installers, please contact our Marketing Department on 01684 853500.

202 Non-thermally Broken Commercial Entrance Door & Framing

PROFILE IDENTIFICATION & INERTIA VALUES

This page gives information on the inertia values of the integral mullions, transoms and coupling mullions. BS 6399 must be used to calculate the inertia value required.

| | | | | | | | | | | | |
|------|--|---|------|--|--|------|--|--|------|--|---|
| 2266 | | Inertia mm ⁴ ← 881,614 → 124,111 | 2953 | | Inertia mm ⁴ ← 258,879 → 21,539 | 2963 | | Inertia mm ⁴ ← 175,453 → 148,935 | 2996 | | Inertia mm ⁴ ← 898,980 → 146,002 |
| 2267 | | Inertia mm ⁴ ← 242,231 → 3,874 | 2954 | | Inertia mm ⁴ ← 244,879 → 1,523 | 2973 | | Inertia mm ⁴ ← 113,637 → 40,699 | 2997 | | Inertia mm ⁴ ← 938,183 → 128,398 |
| 2300 | | Inertia mm ⁴ ← 974,532 → 262,868 | 2955 | | Inertia mm ⁴ ← 899,831 → 158,495 | 2981 | | Inertia mm ⁴ ← 976,452 → 129,124 | 2998 | | Inertia mm ⁴ ← 255,855 → 8,620 |
| 2301 | | Inertia mm ⁴ ← 974,552 → 289,812 | 2956 | | Inertia mm ⁴ ← 939,842 → 127,464 | 2982 | | Inertia mm ⁴ ← 761,493 → 74,425 | 8011 | | Inertia mm ⁴ ← 62,074 → 1,985 |
| 2302 | | Inertia mm ⁴ ← 149,902 → 149,902 | 2957 | | Inertia mm ⁴ ← 837,136 → 122,850 | 2983 | | Inertia mm ⁴ ← 270,595 → 10,948 | 8016 | | Inertia mm ⁴ ← 44,803 → 2,761 |
| 2526 | | Inertia mm ⁴ ← 66,237 → 66,237 | 2958 | | Inertia mm ⁴ ← 265,589 → 2,586 | 2987 | | Inertia mm ⁴ ← 660,816 → 35,916 | 8017 | | Inertia mm ⁴ ← 293,526 → 44,753 |
| 2757 | | Inertia mm ⁴ ← 246,457 → 1,636 | 2960 | | Inertia mm ⁴ ← 917,155 → 135,039 | 2991 | | Inertia mm ⁴ ← 1710,403 → 691,812 | 8018 | | Inertia mm ⁴ ← 249,594 → 18,847 |
| 2951 | | Inertia mm ⁴ ← 952,037 → 128,306 | 2961 | | Inertia mm ⁴ ← 1717,964 → 627,638 | 2992 | | Inertia mm ⁴ ← 714,142 → 49,997 | 8019 | | Inertia mm ⁴ ← 100,955 → 1,867 |
| 2952 | | Inertia mm ⁴ ← 824,240 → 83,007 | 2962 | | Inertia mm ⁴ ← 650,463 → 31,642 | 2993 | | Inertia mm ⁴ ← 851,559 → 167,070 | 8025 | | Inertia mm ⁴ ← 824,508 → 824,508 |

202 Non-thermally Broken Commercial Entrance Door & Framing

GENERAL ARRANGEMENTS

| Elevation | Page |
|---|-------|
| Centre Pivot Door | 28-29 |
| Standard Stile Options | 30-31 |
| Standard Meeting Stile Options | 32-35 |
| Standard Top Rail Options | 36 |
| Standard Bottom Rail Options | 37 |
| Standard Lay Bar and Mid Rail Options | 38 |
| Standard Door Head/Transom Options - centre pivot | 39 |
| Standard Door Head/Transom Options - rebate | 40 |
| Standard Door Transom Options | 41 |
| Standard Door Cill Options - centre pivot | 42 |
| Standard Door Cill Options - rebate | 43 |
| Standard Door Jamb Options - centre pivot | 44 |
| Standard Door Jamb Options - rebate | 45 |
| Standard Fixed Frame Options - head | 46 |
| Standard Fixed Frame Options - transom | 47 |
| Standard Fixed Frame Options - mid rail | 48 |
| Standard Fixed Frame Options - cill and sub cill | 49-50 |
| Standard Fixed Frame Options - jambs | 51 |
| Standard Fixed Frame Options - mullion | 52 |
| Standard Fixed Frame Options - corner post | 53 |
| Standard Fixed Frame Options - 75mm framing | 54 |

These drawings illustrate a number of the available profile combinations. Other combinations are available please consult Sapa Building Systems for further details.

GENERAL ARRANGEMENTS

Centre Pivot Door

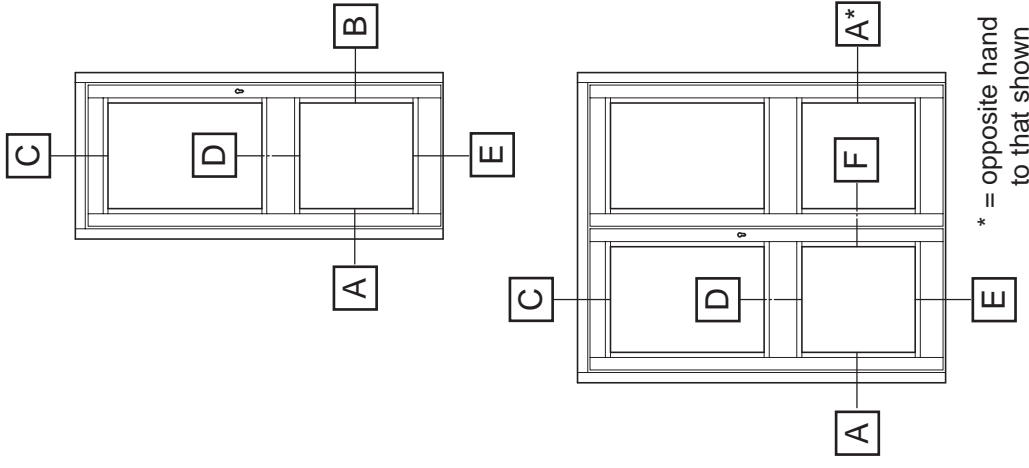
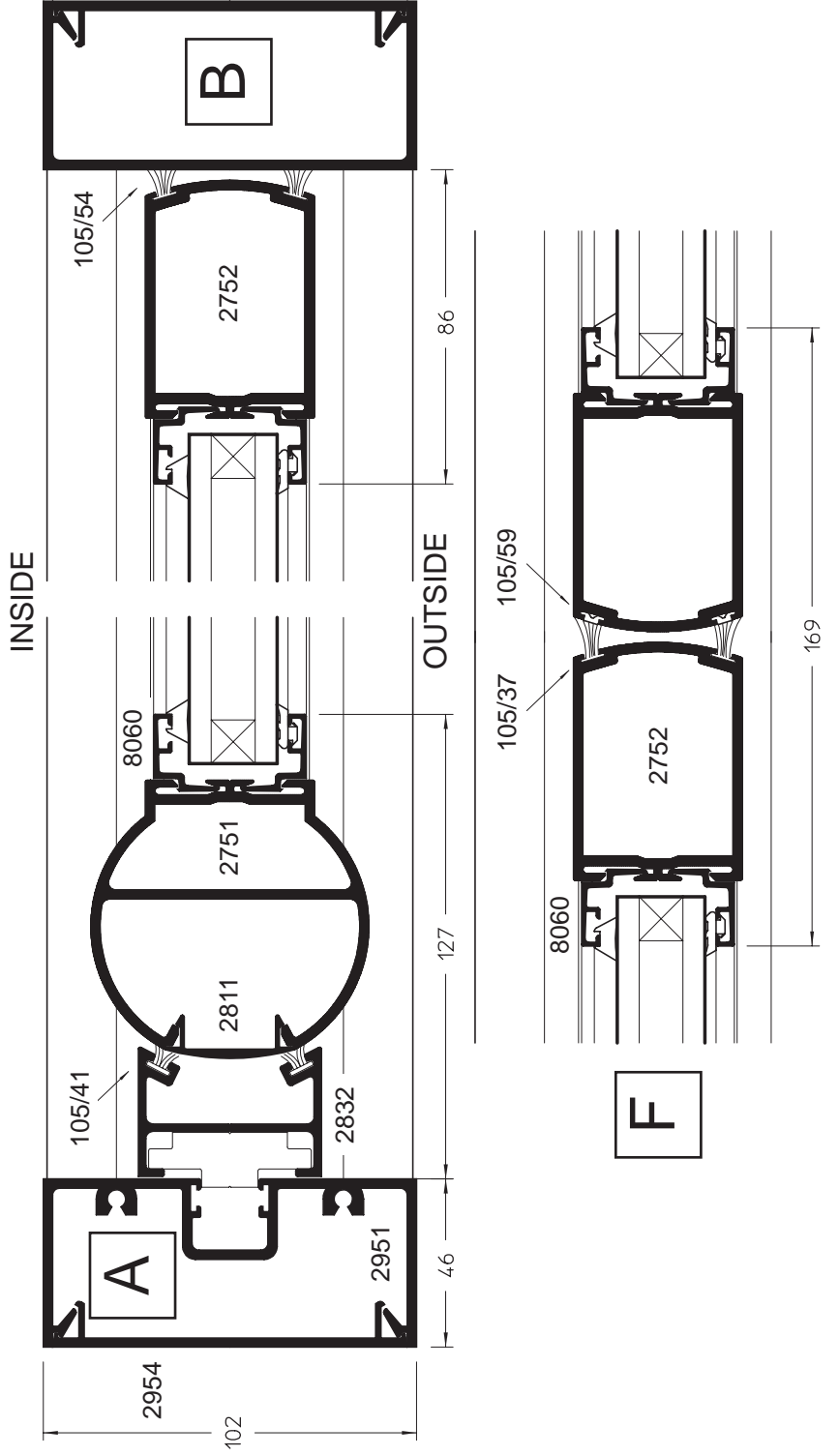

* = opposite hand to that shown

Centre Pivot Door

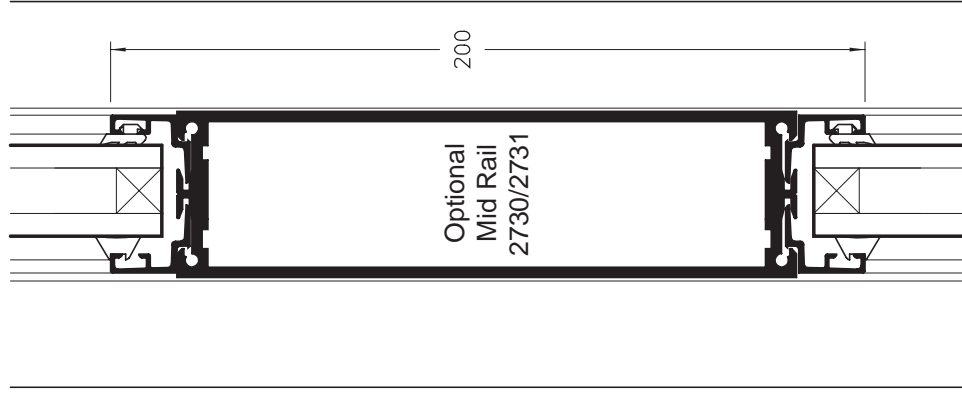
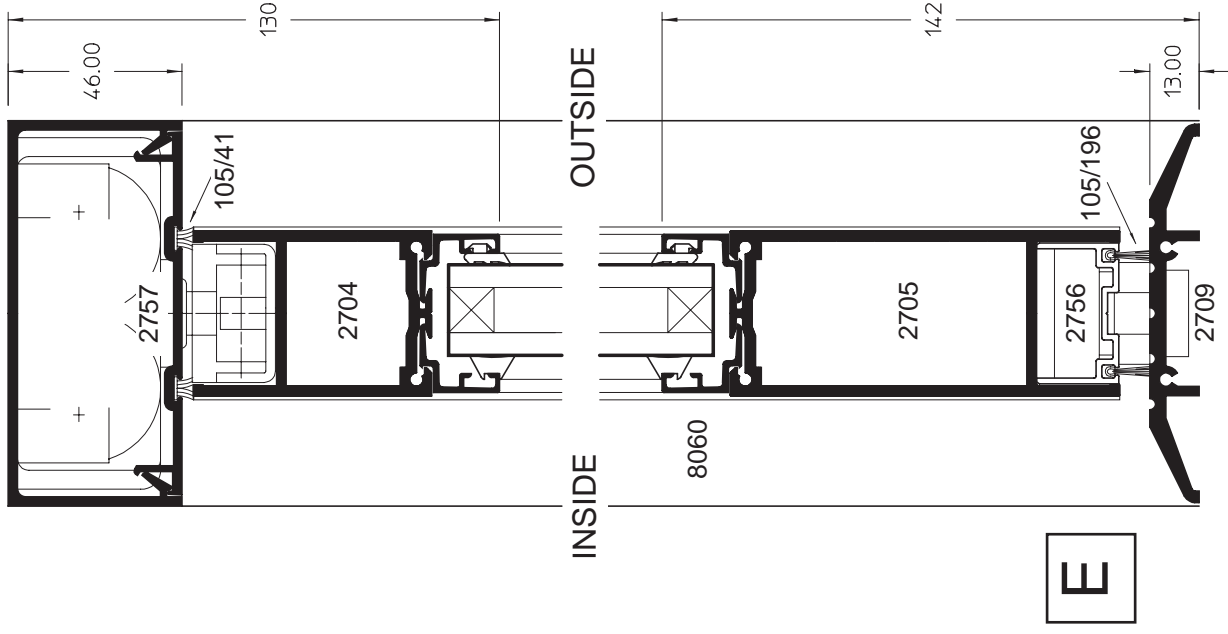

D

D

202 Non-thermally Broken Commercial Entrance Door & Framing

GENERAL ARRANGEMENTS

Standard Stile Options

- Centre Pivot & Rebate
- Centre Pivot Shown

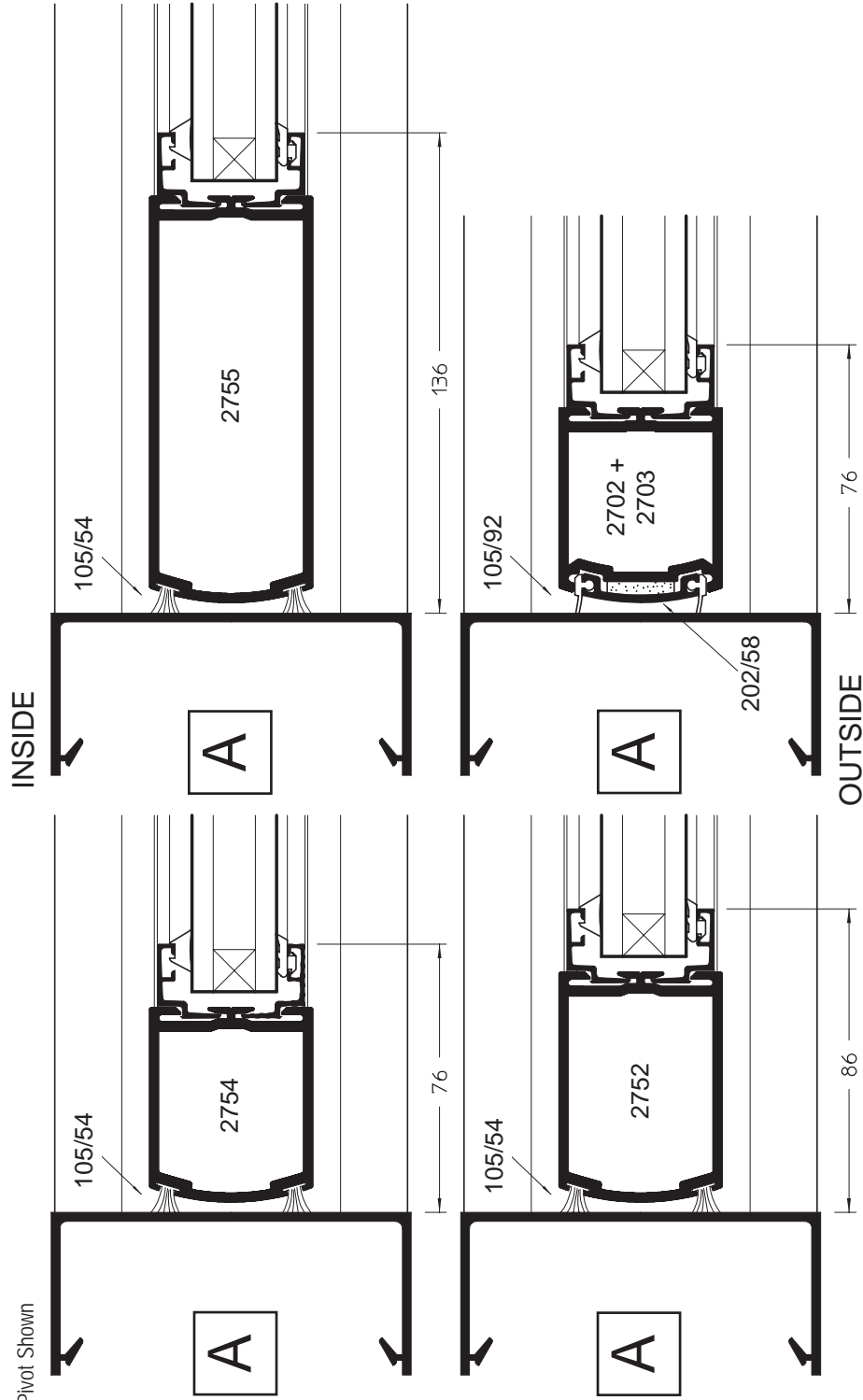

* = opposite hand to that shown

GENERAL ARRANGEMENTS

Standard Stile Options

Centre Pivot & Rebate

Centre Pivot Shown

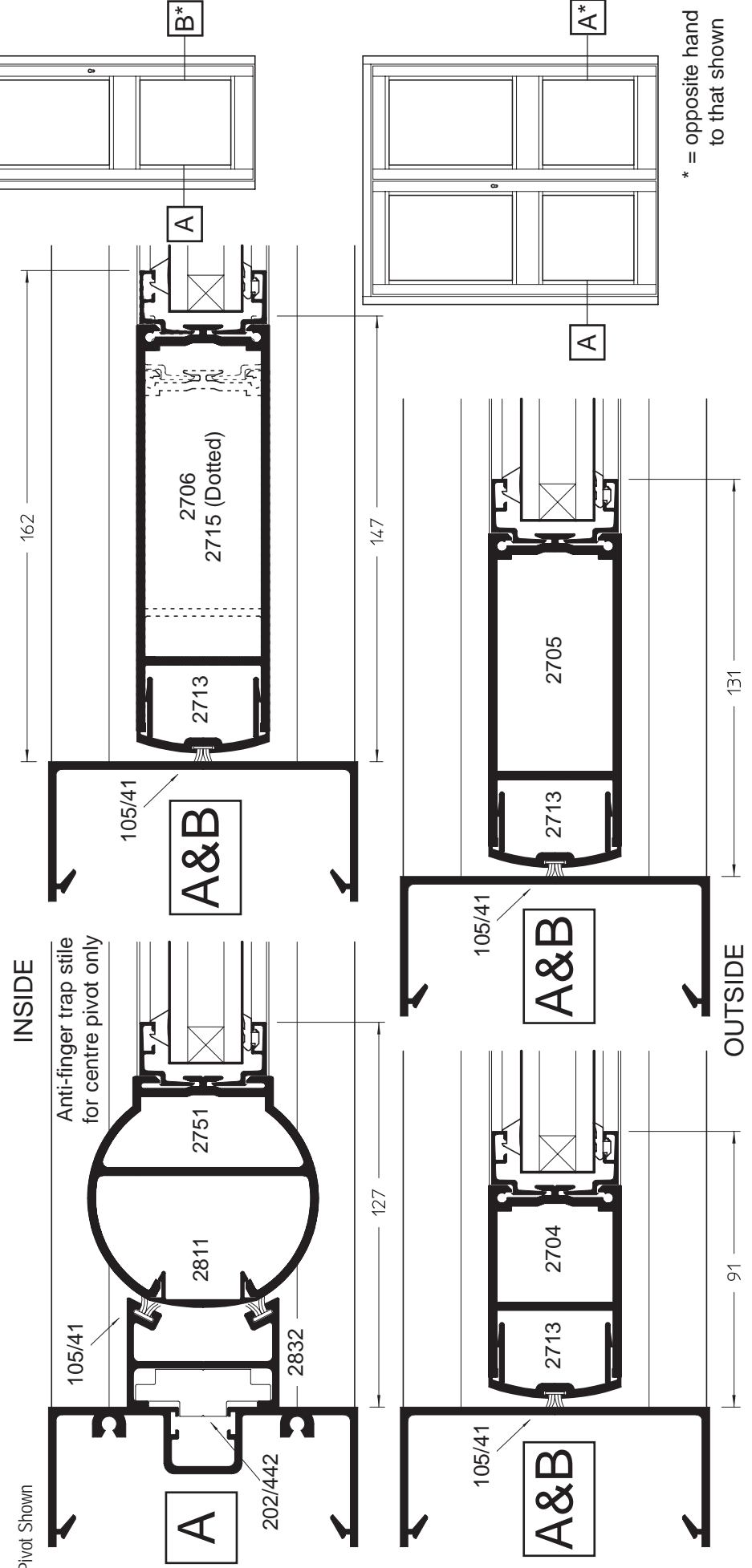

202 Non-thermally Broken Commercial Entrance Door & Framing

GENERAL ARRANGEMENTS

Standard Meeting Stile Options
Centre Pivot & Rebate

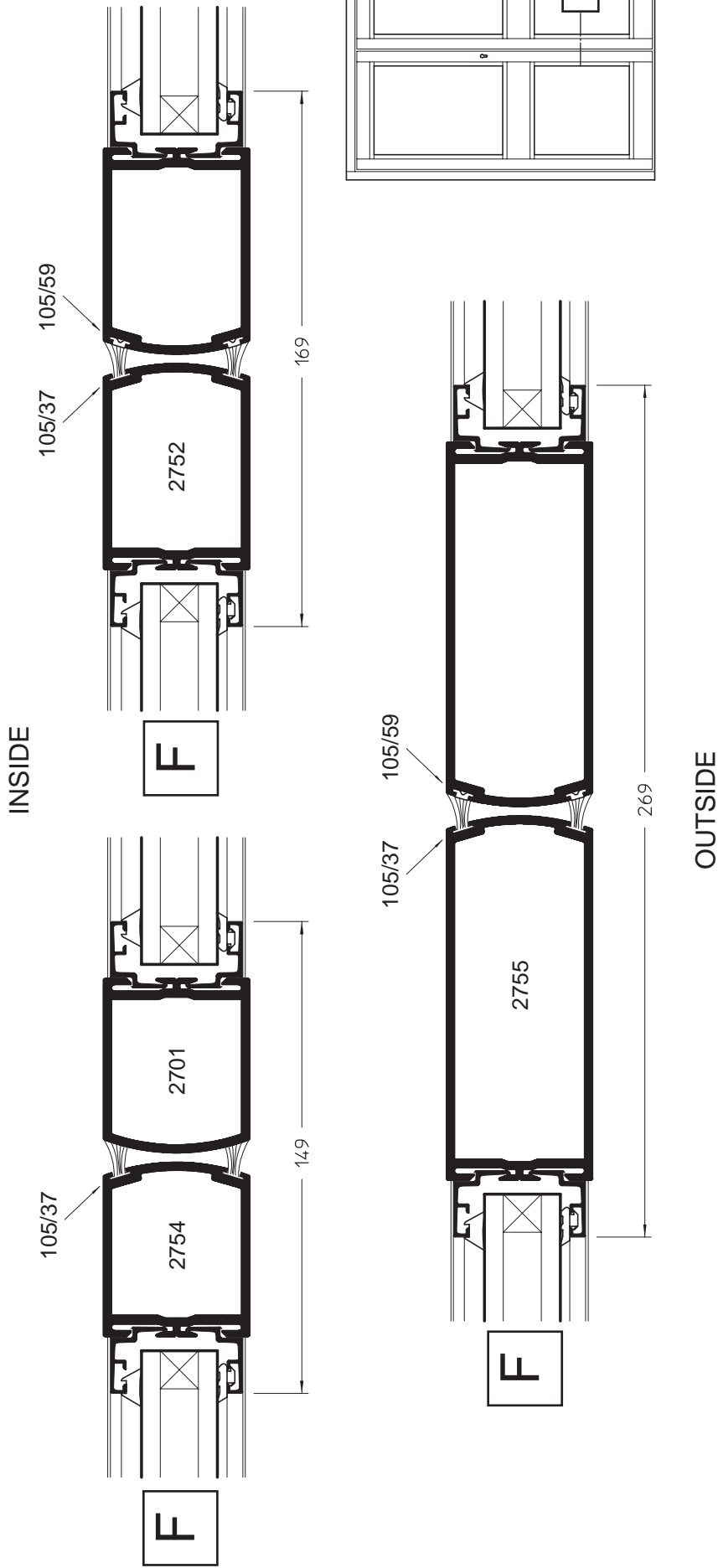

202 Non-thermally Broken Commercial Entrance Door & Framing

GENERAL ARRANGEMENTS

Standard Meeting Stile Options

Centre Pivot & Rebate



Open in doors shown,
Mirror illustration for
open out doors

INSIDE

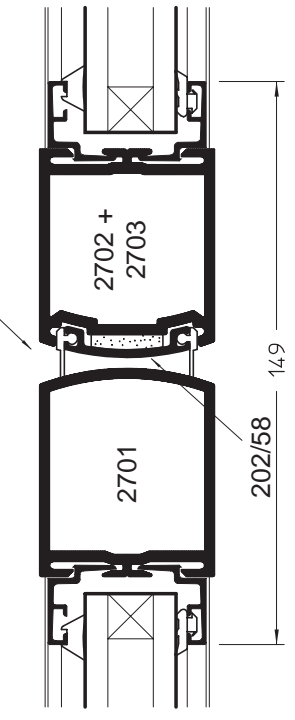
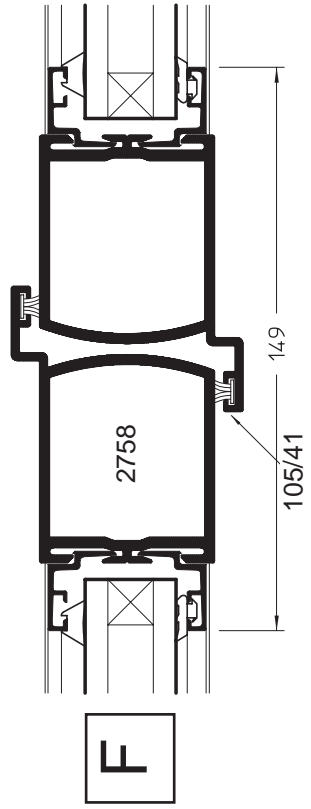
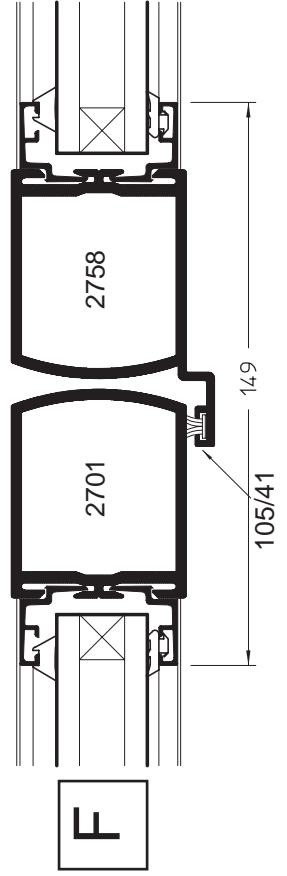
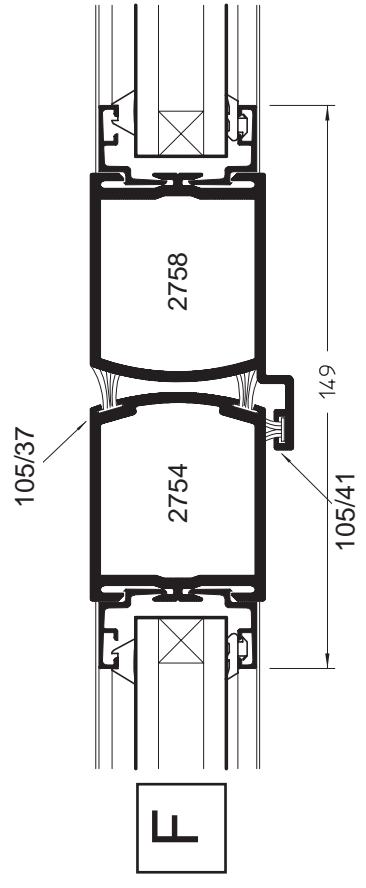

OUTSIDE

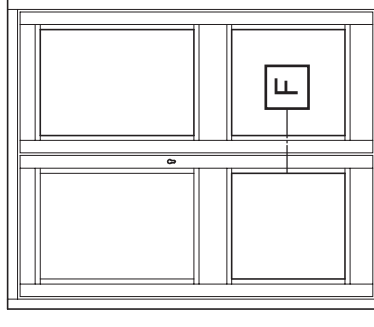

202 Non-thermally Broken Commercial Entrance Door & Framing

GENERAL ARRANGEMENTS

Standard Meeting Stile Options

Centre Pivot & Rebate

Open in doors shown,
Mirror illustration for
open out doors

INSIDE

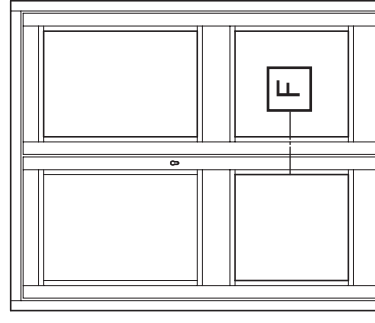
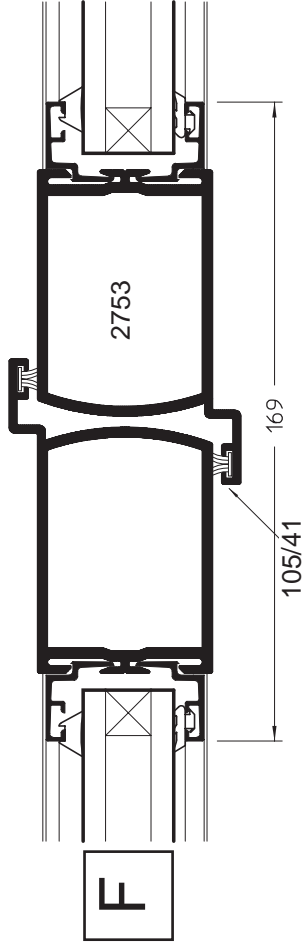
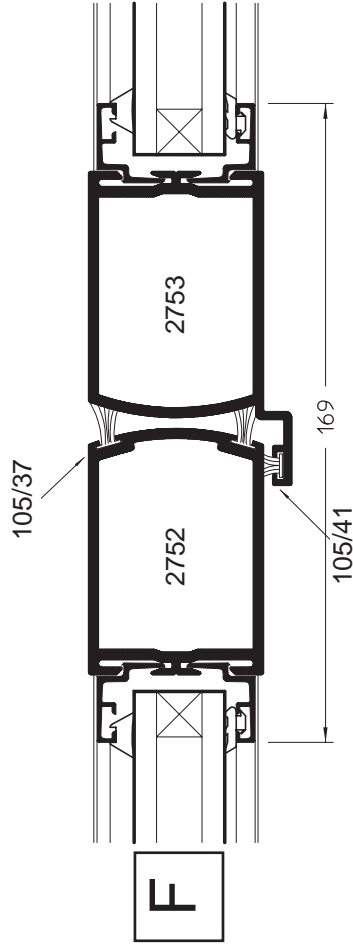

OUTSIDE

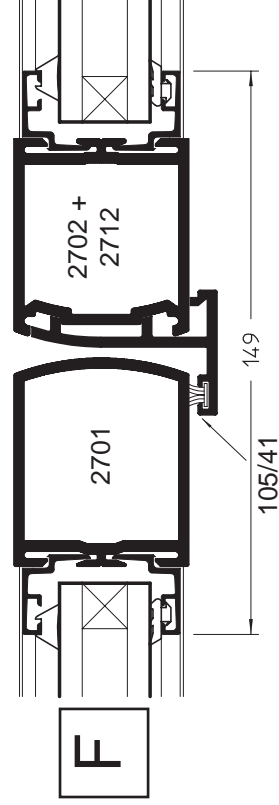
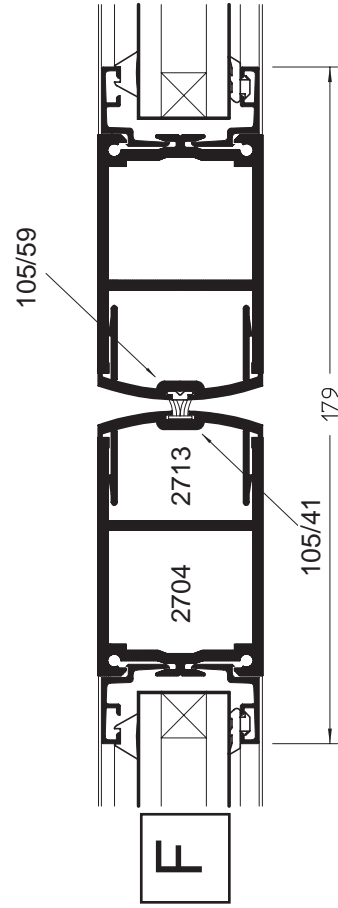

GENERAL ARRANGEMENTS

Standard Meeting Stile Options

Centre Pivot & Rebate

INSIDE

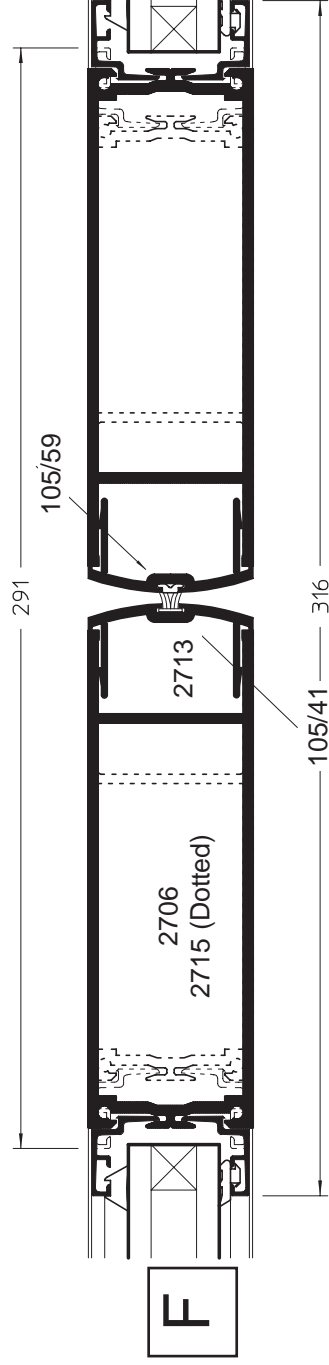
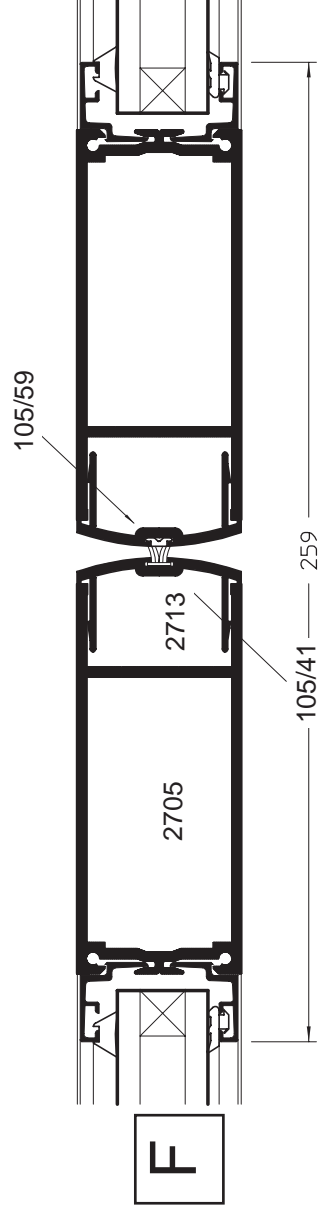

OUTSIDE

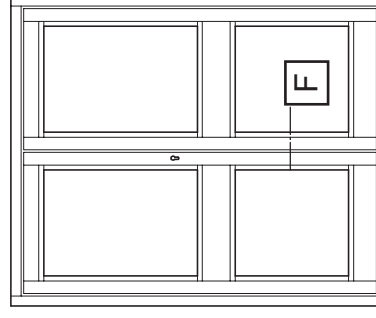

202 Non-thermally Broken Commercial Entrance Door & Framing

GENERAL ARRANGEMENTS

Standard Top Rail Options

Centre Pivot & Rebate

Centre Pivot Shown

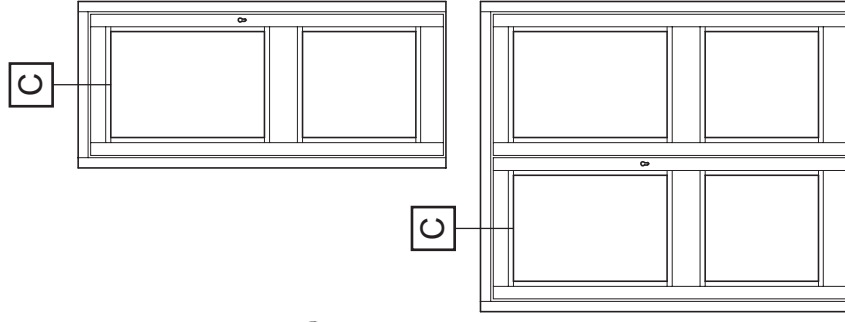
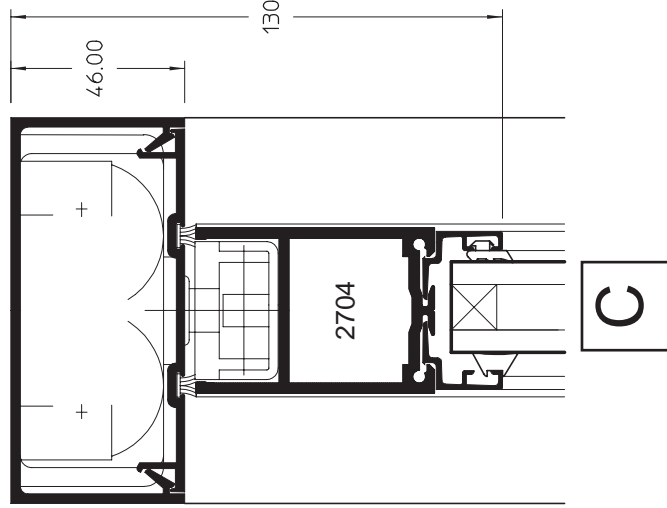
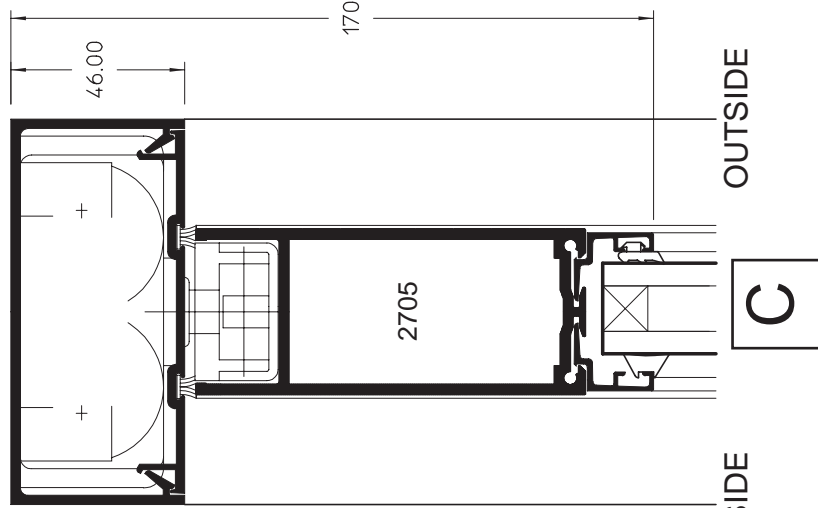
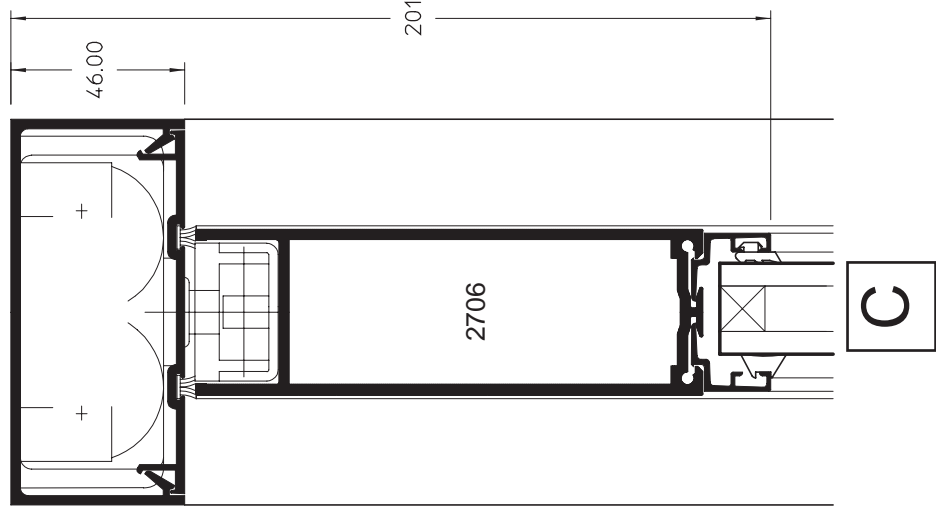

GENERAL ARRANGEMENTS

Standard Bottom Rail Options

Centre Pivot & Rebate

Centre Pivot Shown

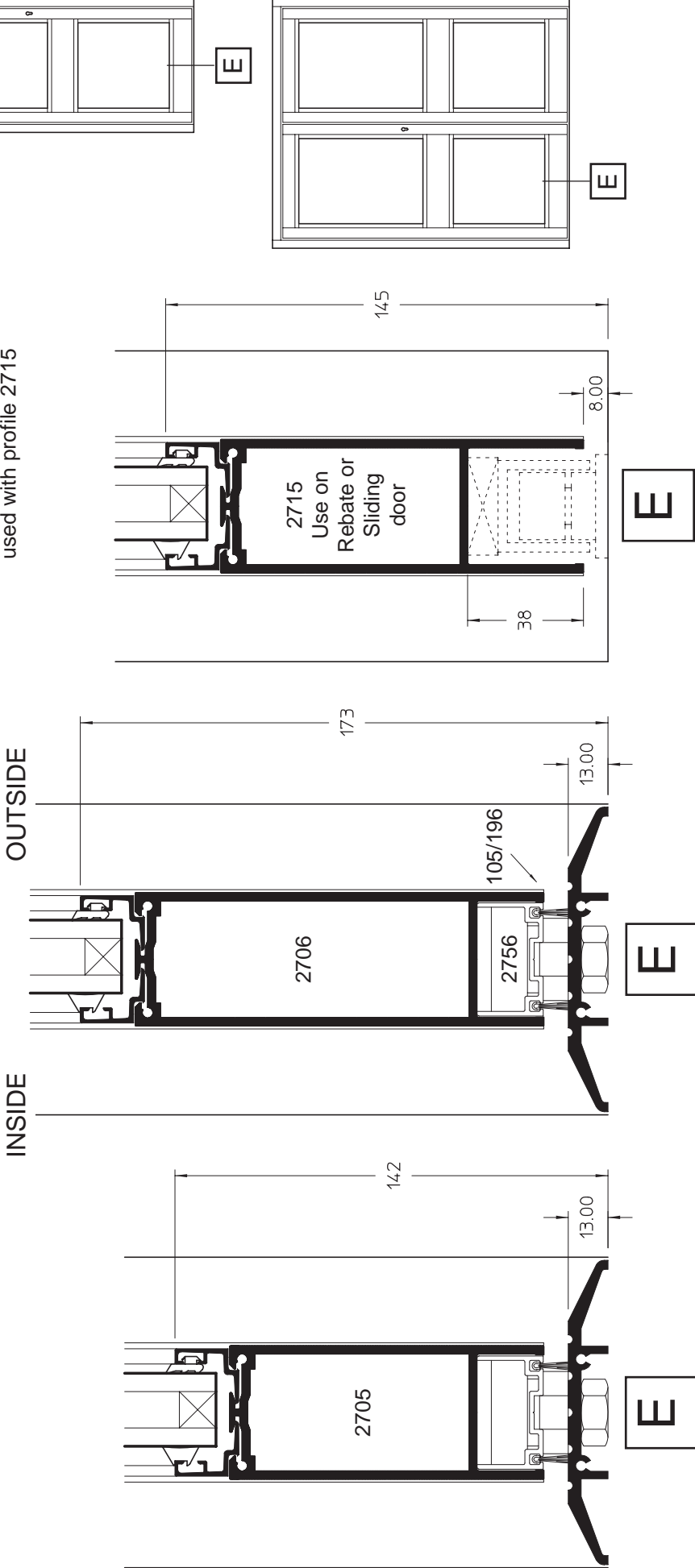

Weather-strip carrier profile 2756 cannot be used with profile 2715

202 Non-thermally Broken Commercial Entrance Door & Framing

GENERAL ARRANGEMENTS

Standard Lay Bar & Mid Rail Options

Centre Pivot & Rebate

Centre Pivot Shown

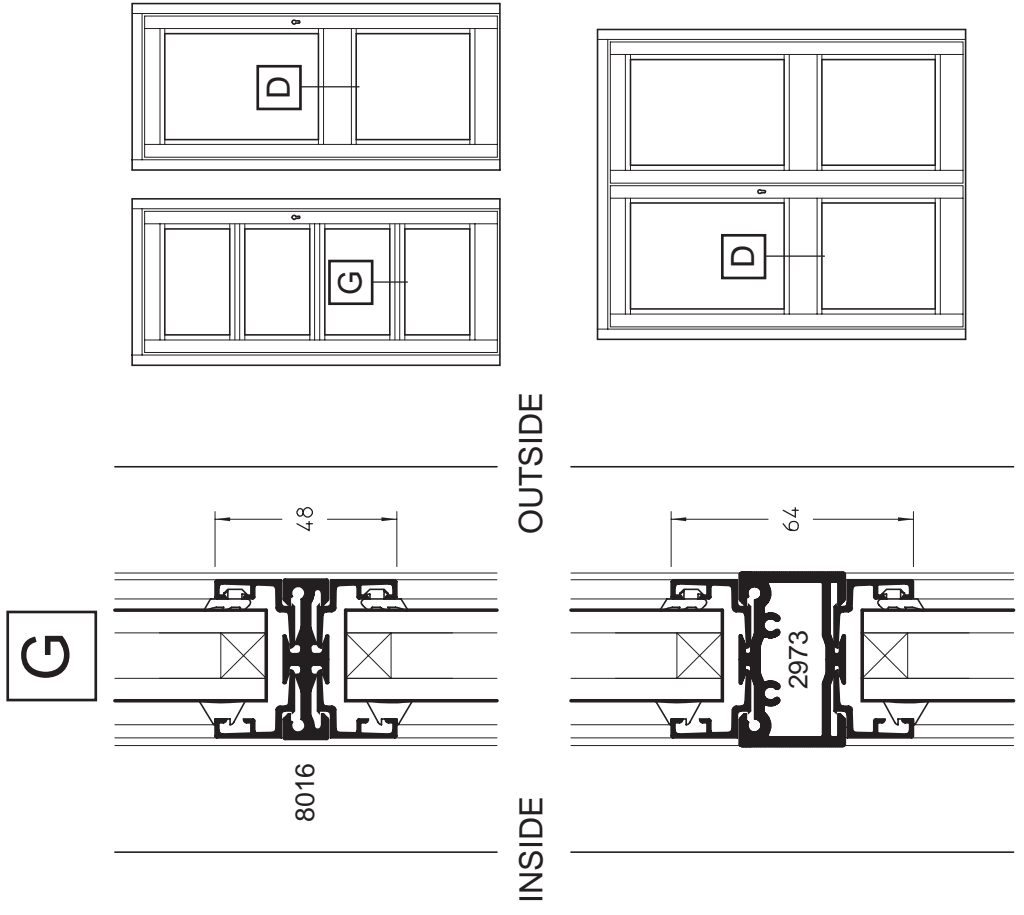
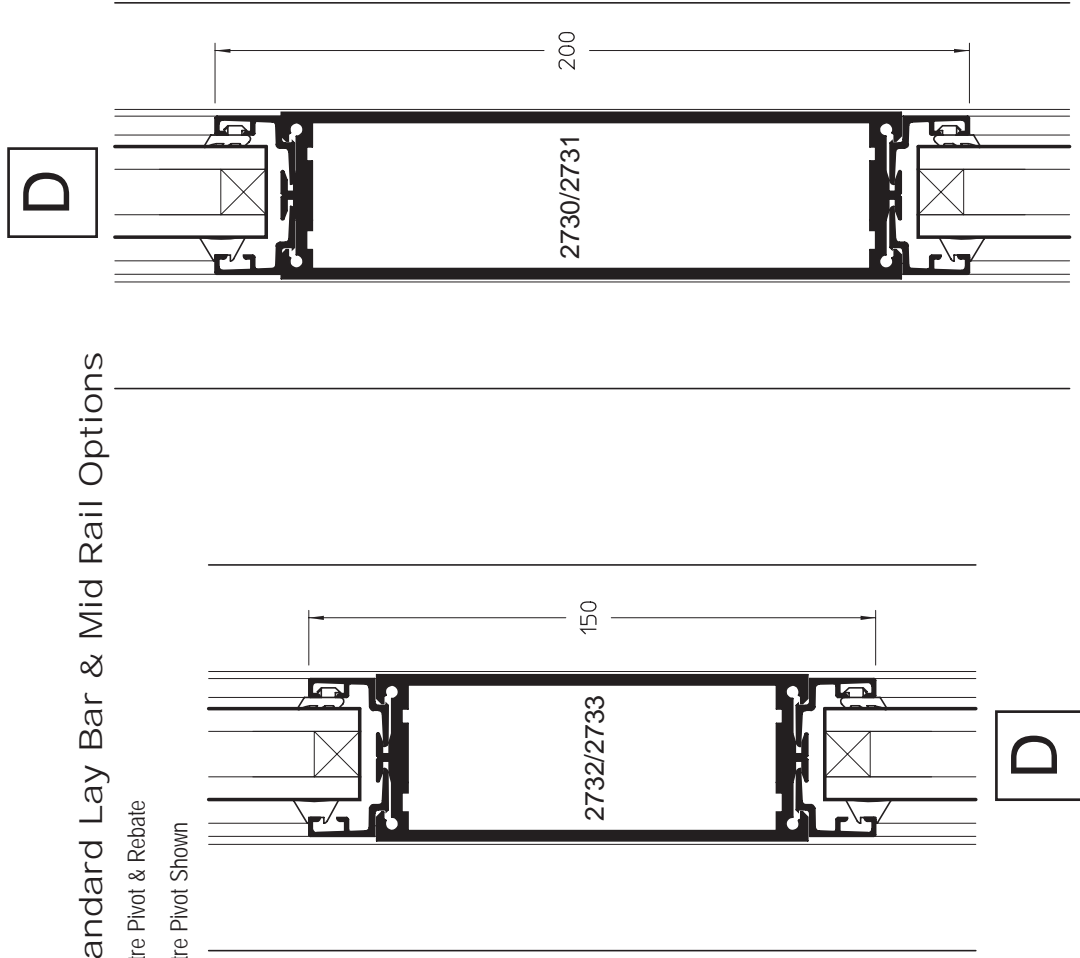

Standard Door Head/Transom Options

Centre Pivot

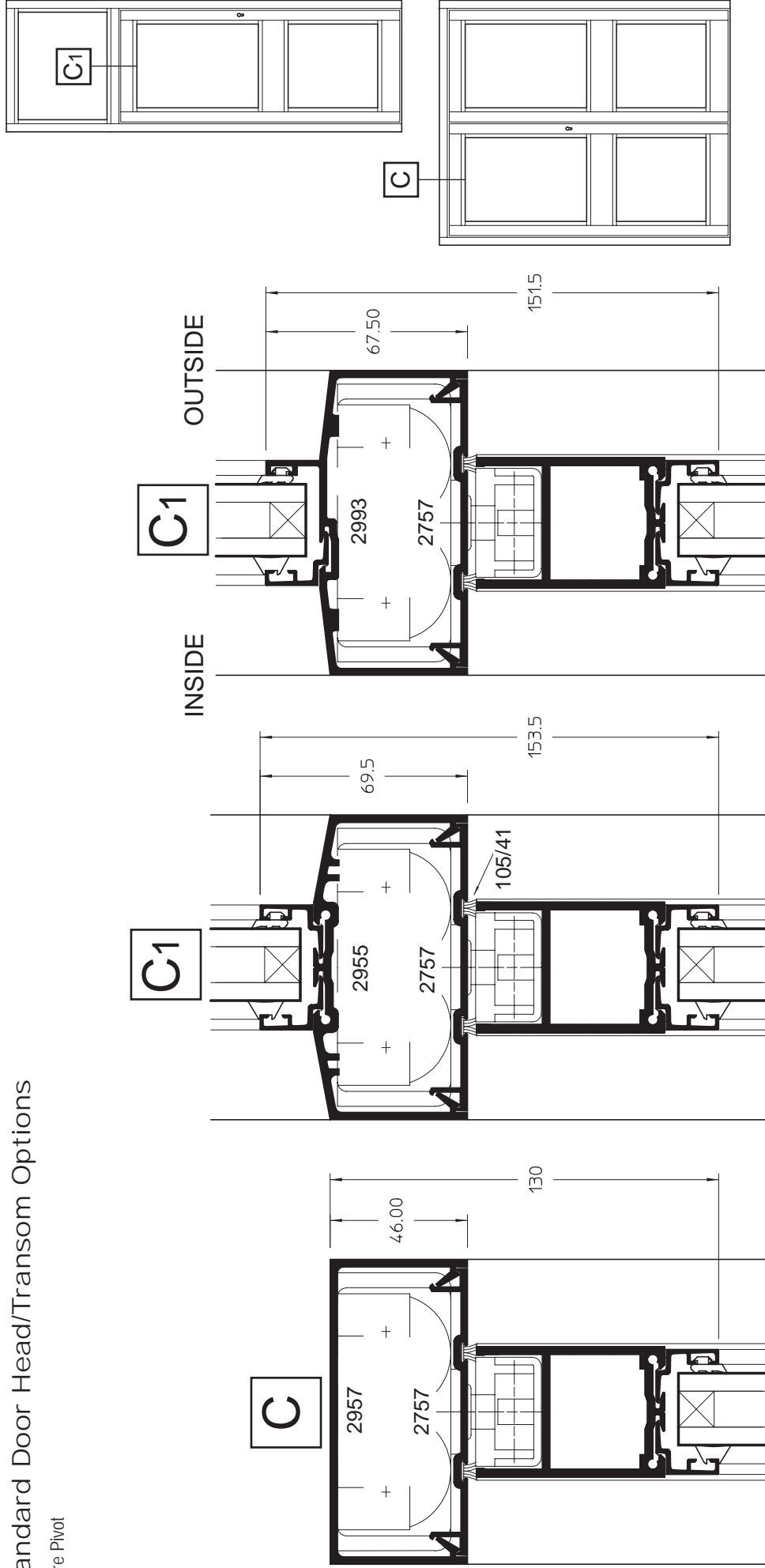

202 Non-thermally Broken Commercial Entrance Door & Framing

GENERAL ARRANGEMENTS

Standard Door Head/Transom Options

Rebate

Open out door shown,
Mirror illustration for open
in door, with the exception
of profiles 2981 & 2984

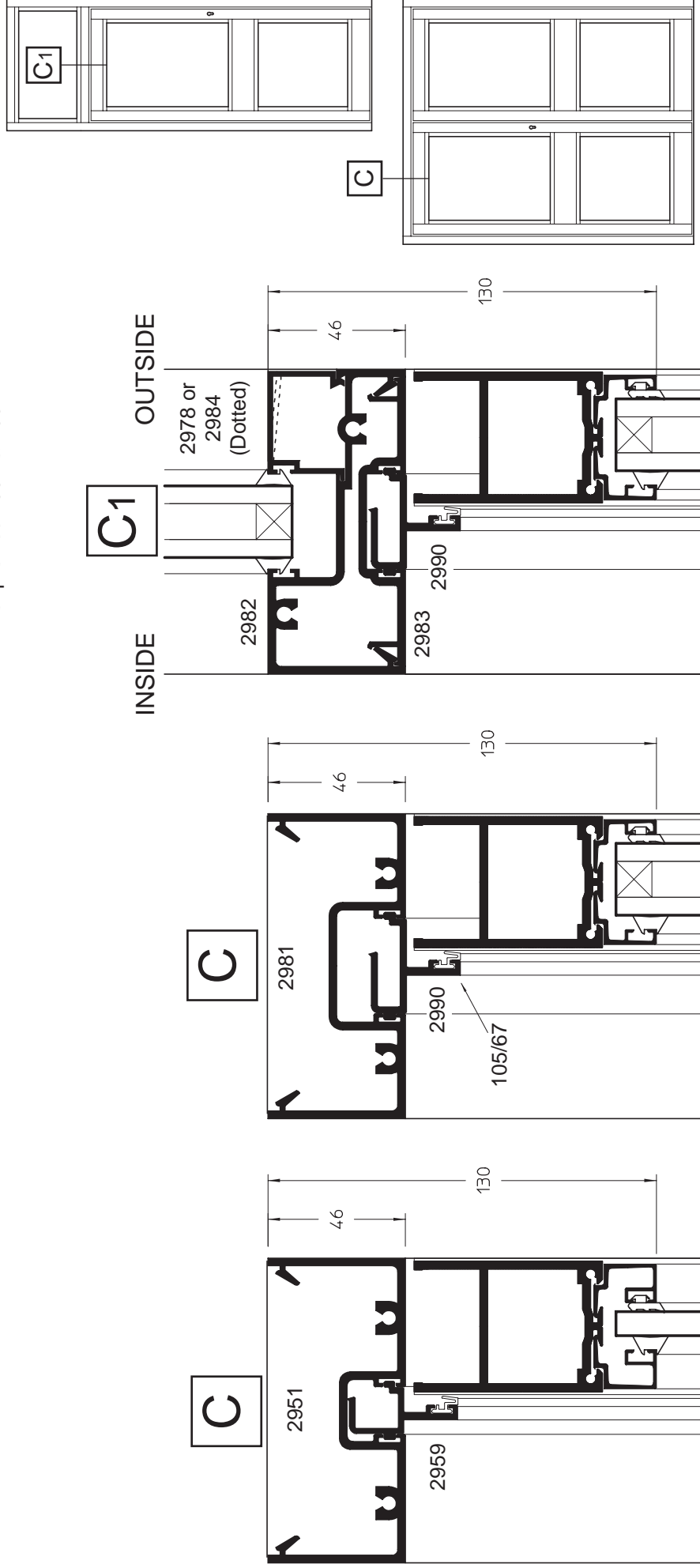

GENERAL ARRANGEMENTS

Standard Door Transom Options

Rebate

Open out door shown, Mirror illustration for open in door, with the exception of profiles 2952, 2966 or 2967 & 2996

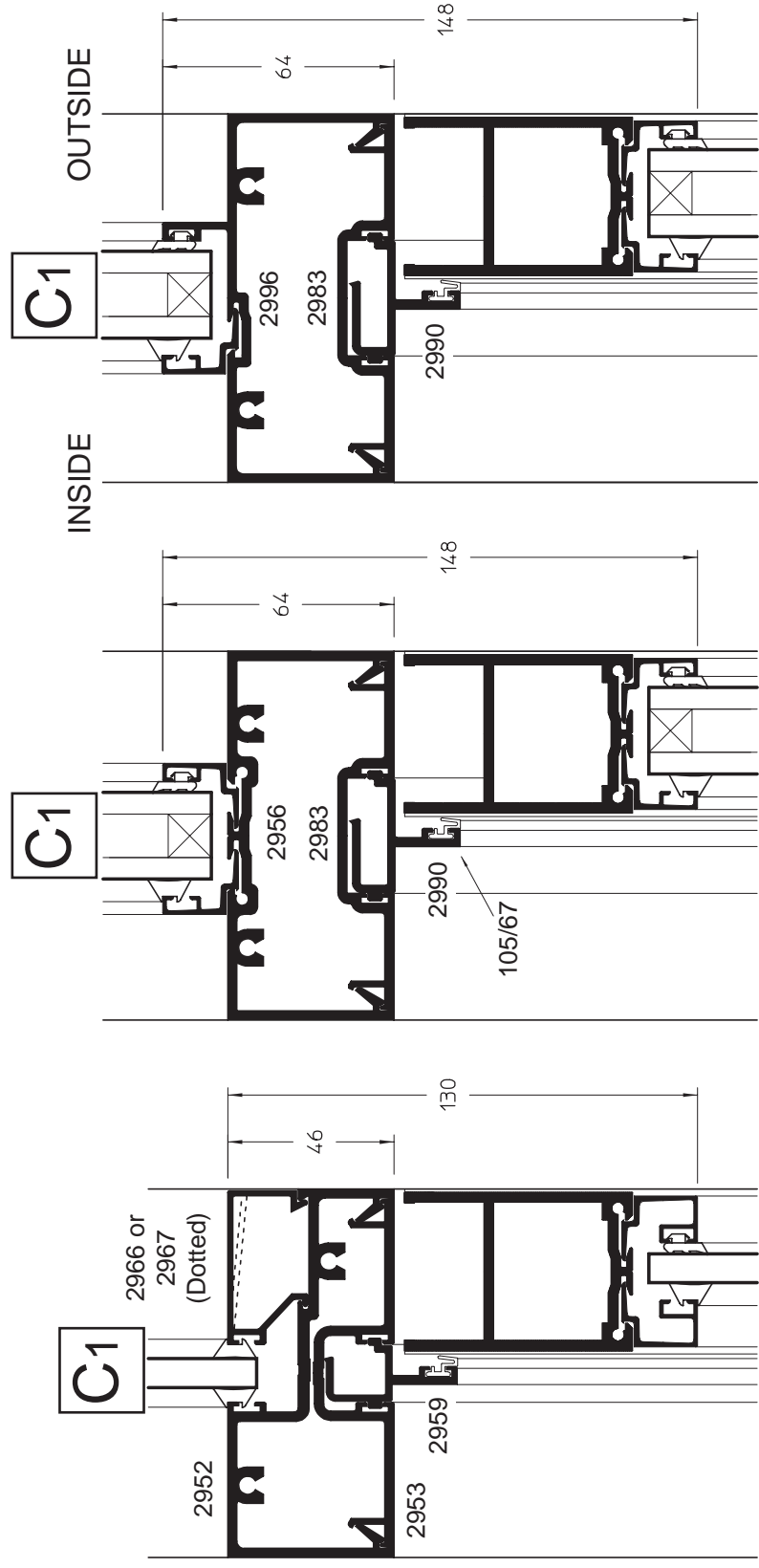
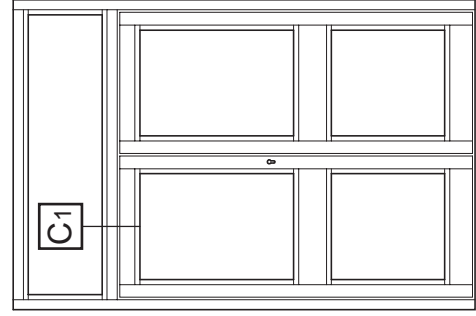
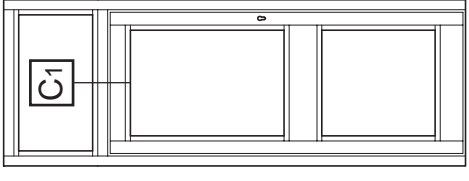

202 Non-thermally Broken Commercial Entrance Door & Framing

GENERAL ARRANGEMENTS

Standard Door Cill Options

Centre Pivot

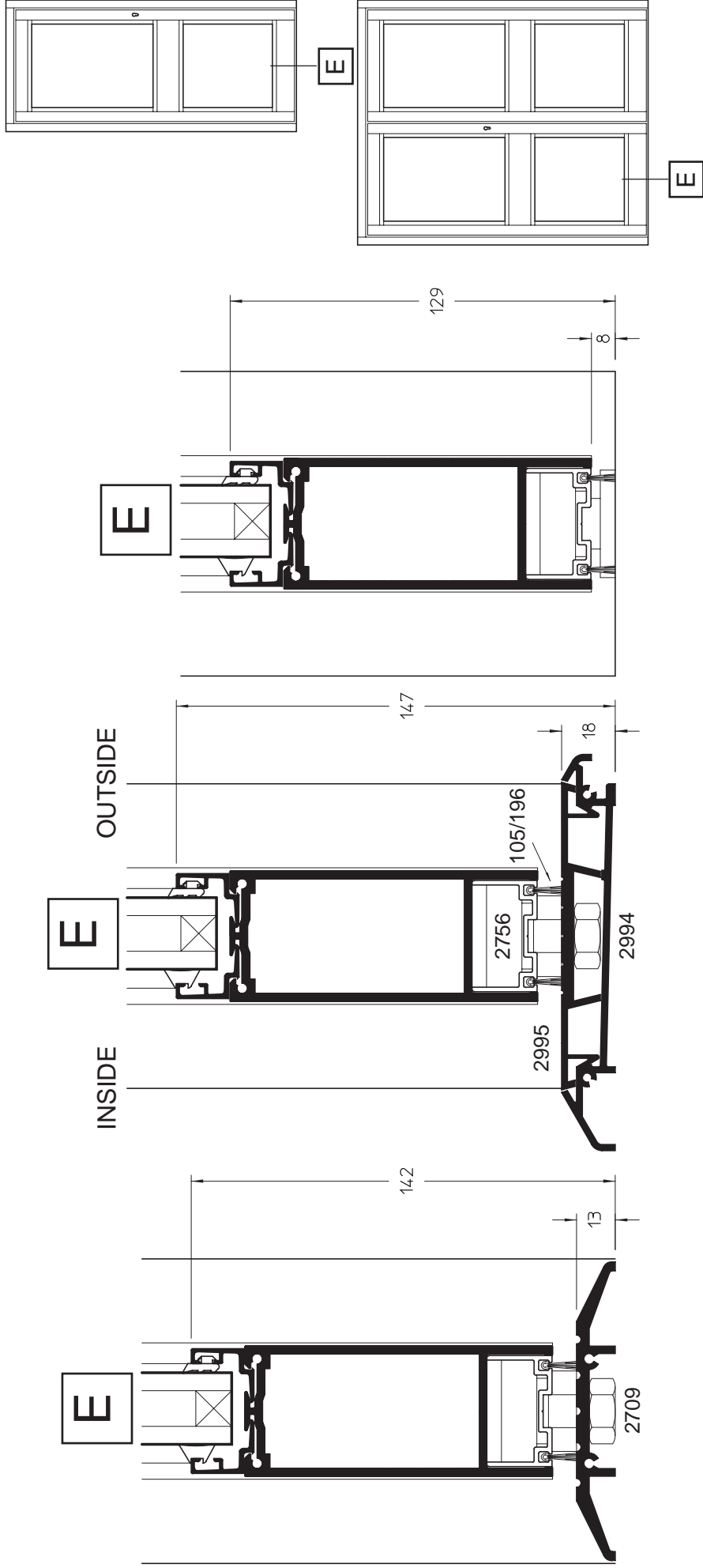

GENERAL ARRANGEMENTS

Standard Door Cill Options

Rebate

Open out door shown,
Mirror illustration for open
in door, with the exception
of profile 2994

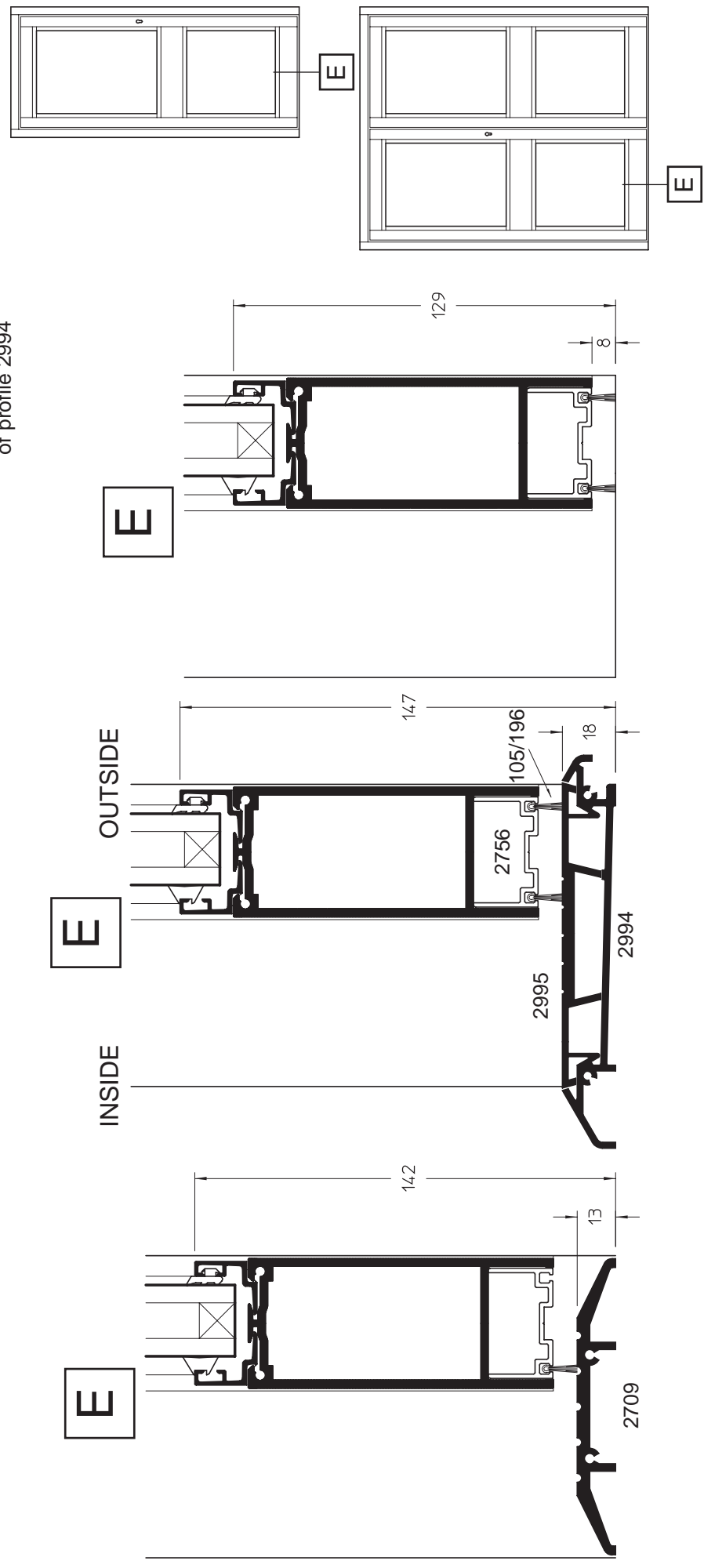

202 Non-thermally Broken Commercial Entrance Door & Framing

GENERAL ARRANGEMENTS

Standard Door Jamb Options

Centre Pivot

* = opposite hand to that shown

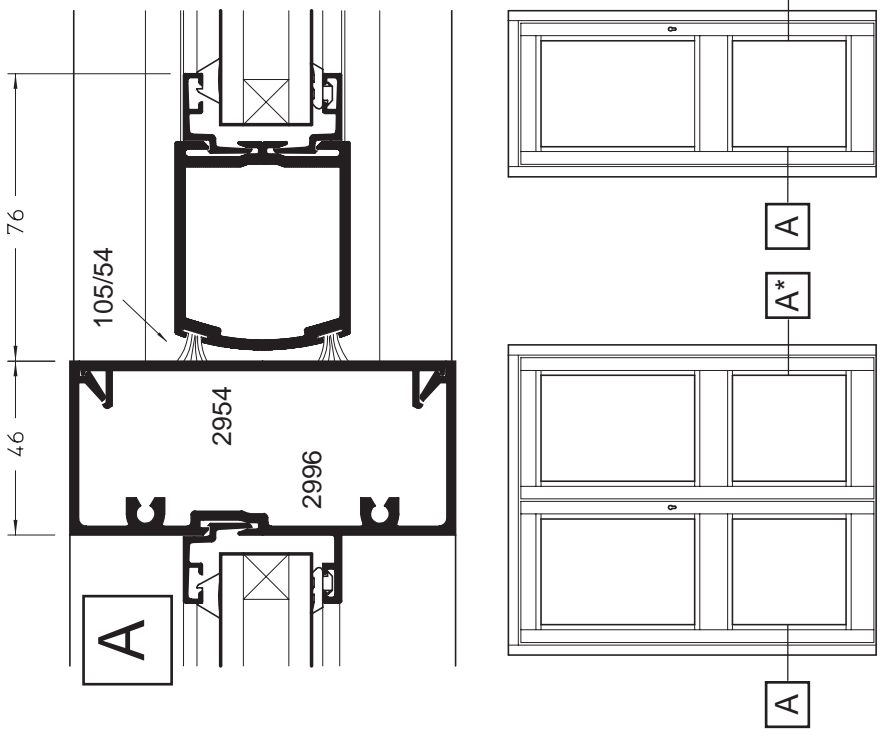
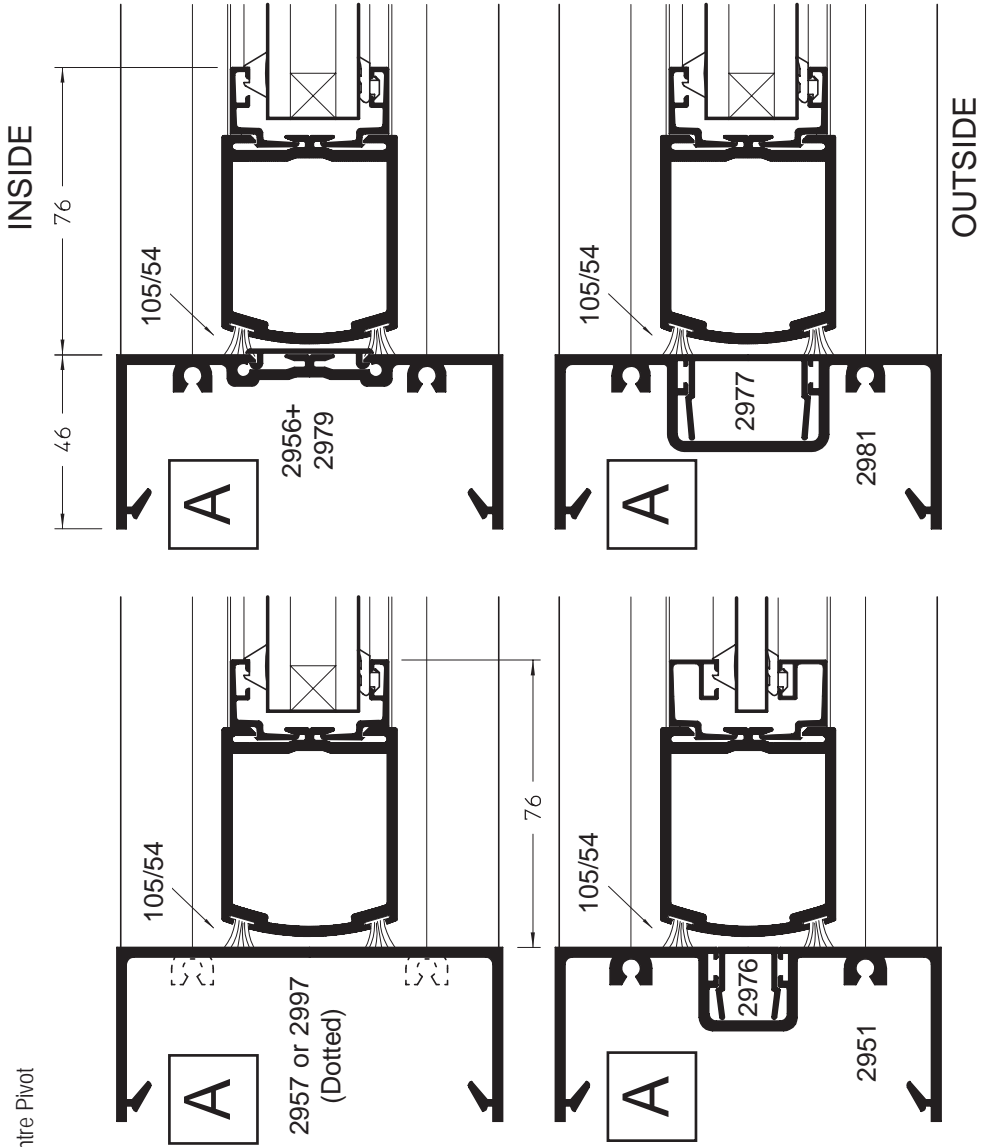

GENERAL ARRANGEMENTS

Standard Door Jamb Options

Rebate

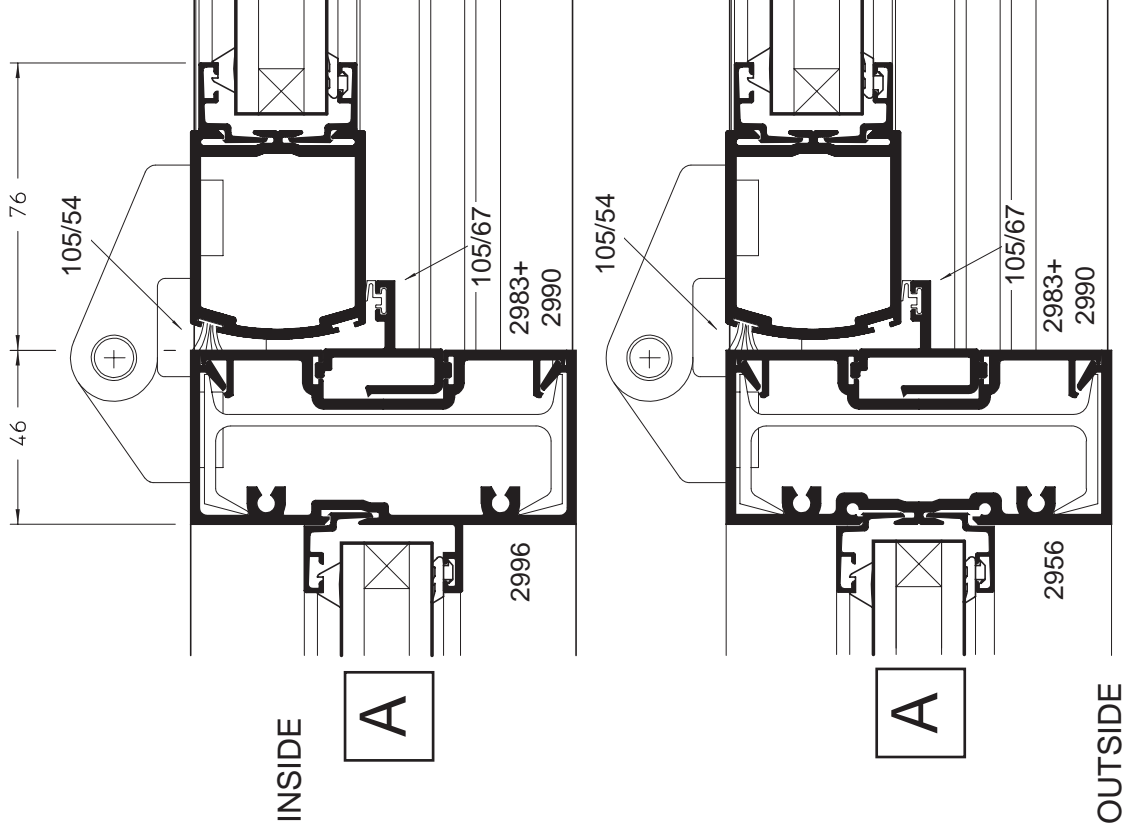

Open in door shown,
Mirror illustration for
open out door, with the
exception of profile 2996

* = opposite hand
to that shown

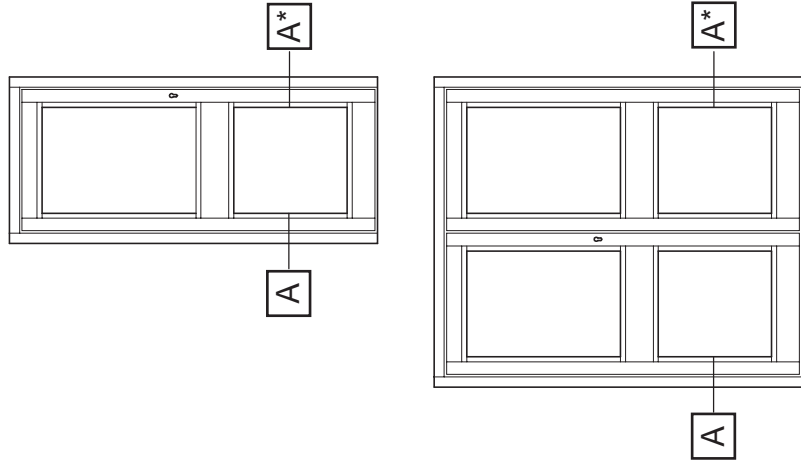

202 Non-thermally Broken Commercial Entrance Door & Framing

GENERAL ARRANGEMENTS

Standard Fixed Frame Options

Head

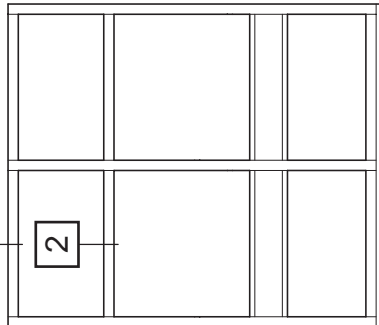
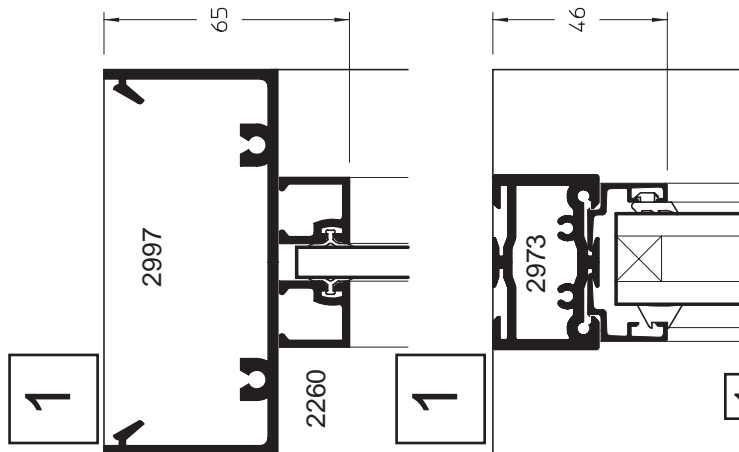
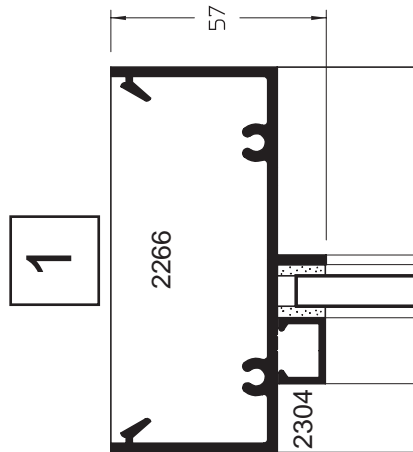
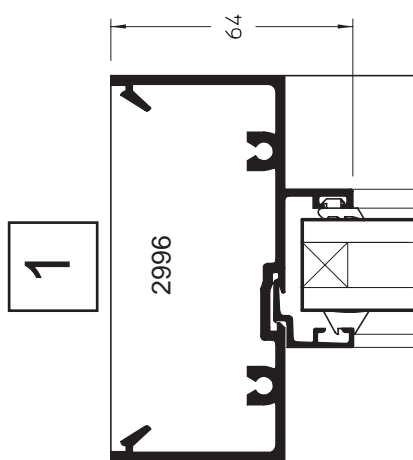
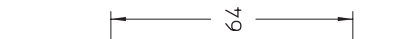
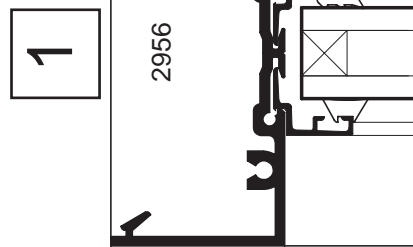
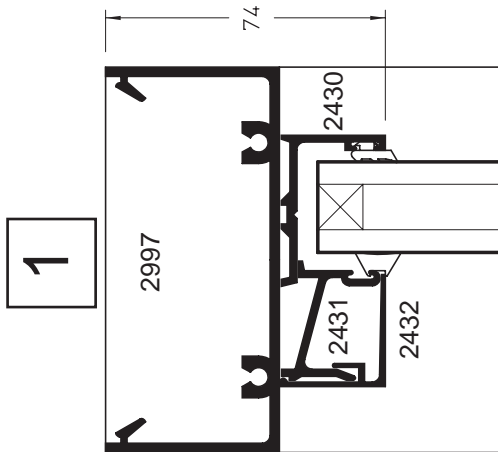
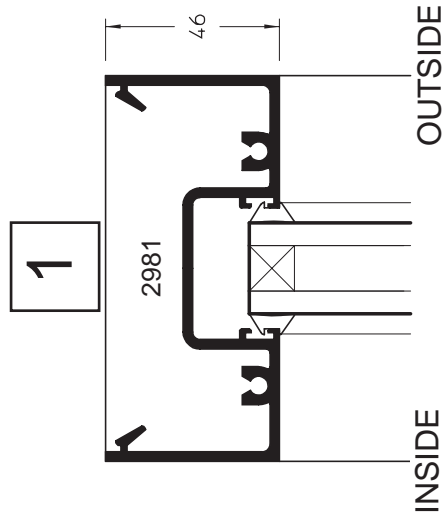
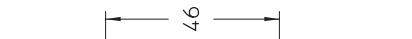
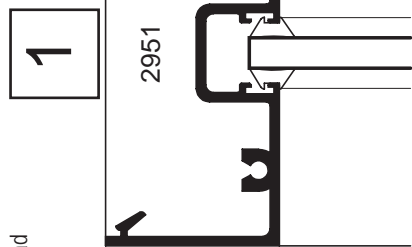

GENERAL ARRANGEMENTS

Standard Fixed Frame Options

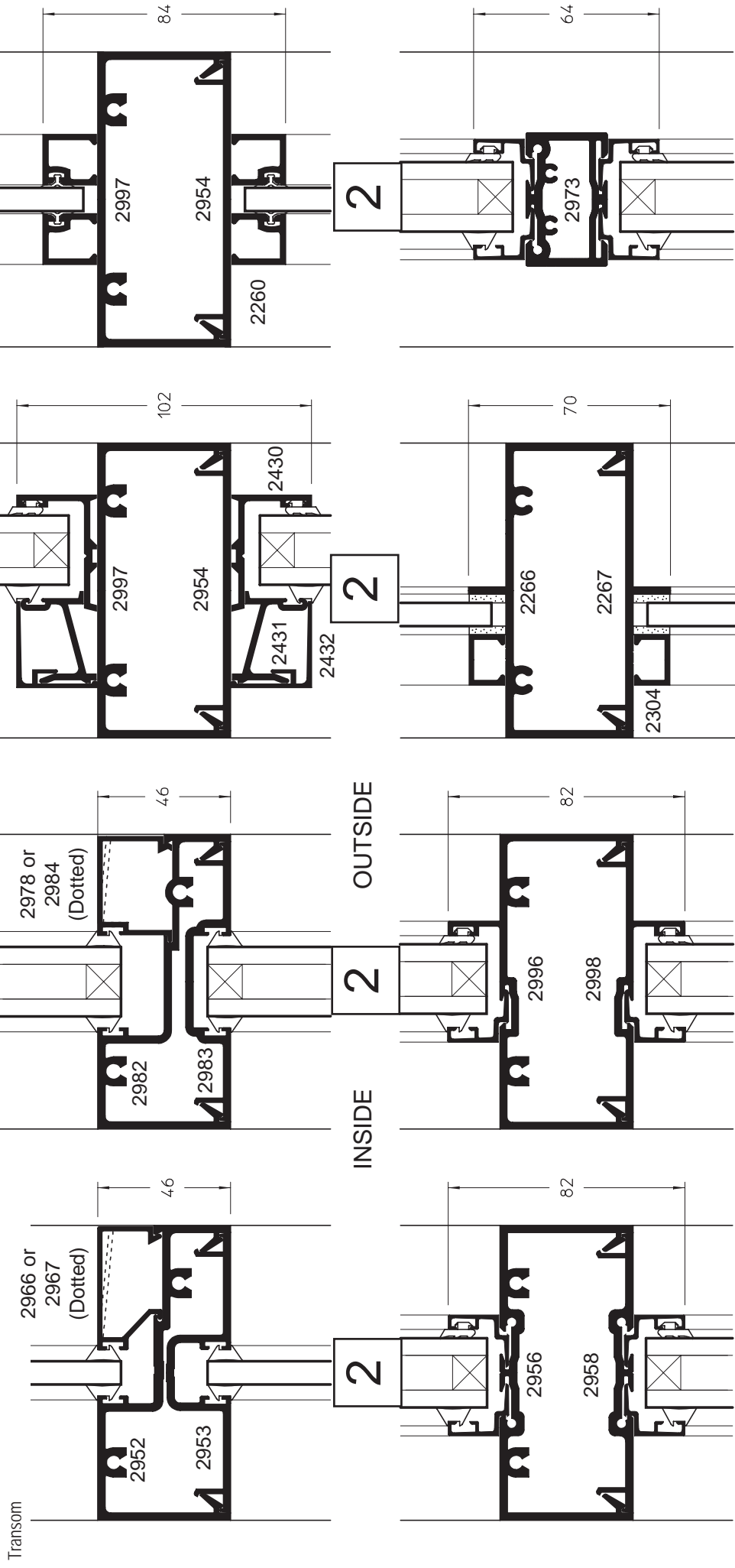

202 Non-thermally Broken Commercial Entrance Door & Framing

GENERAL ARRANGEMENTS

Standard Fixed Frame Options

Mid rail

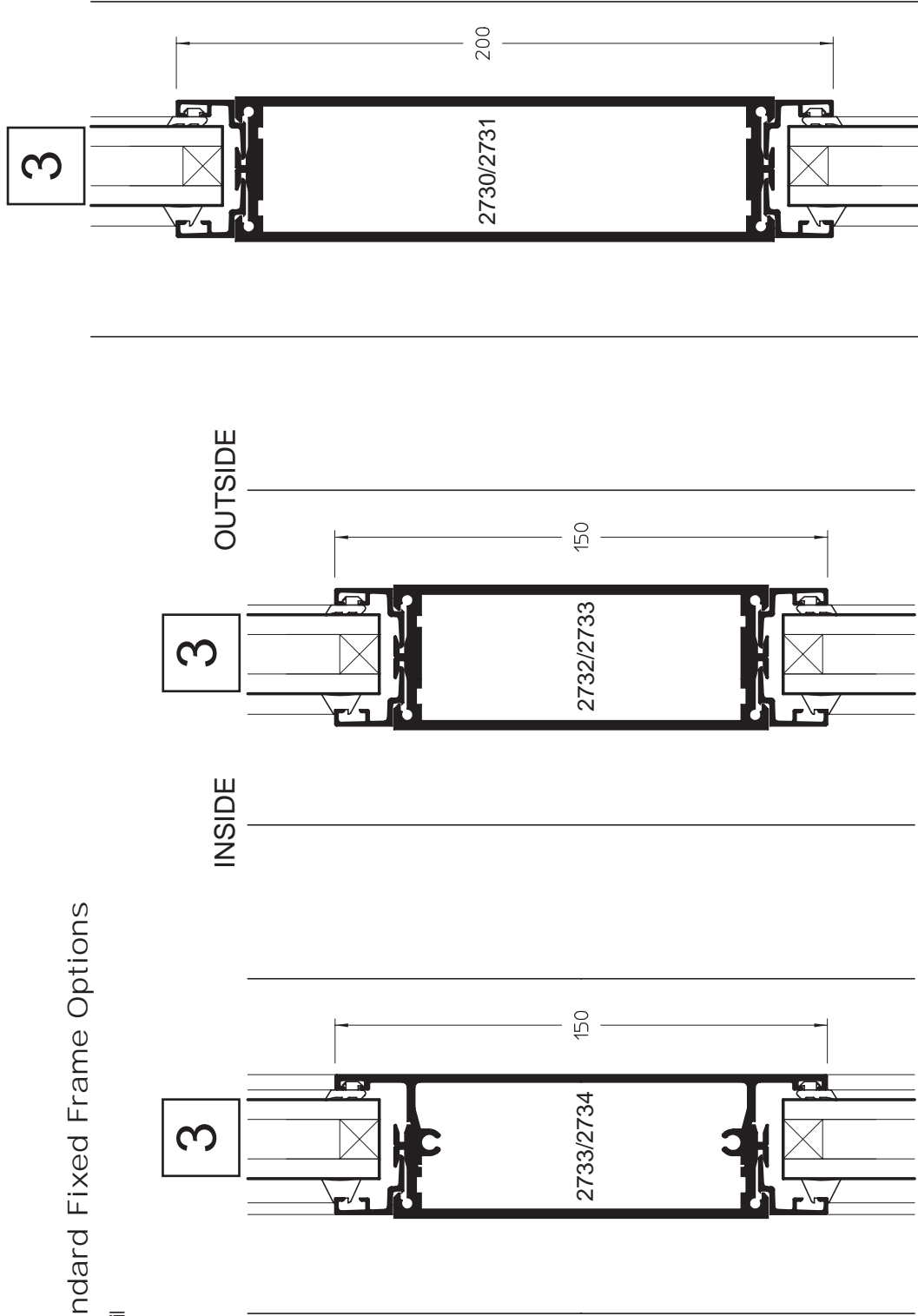

GENERAL ARRANGEMENTS

Standard Fixed Frame Options

Cill & Sub Cill

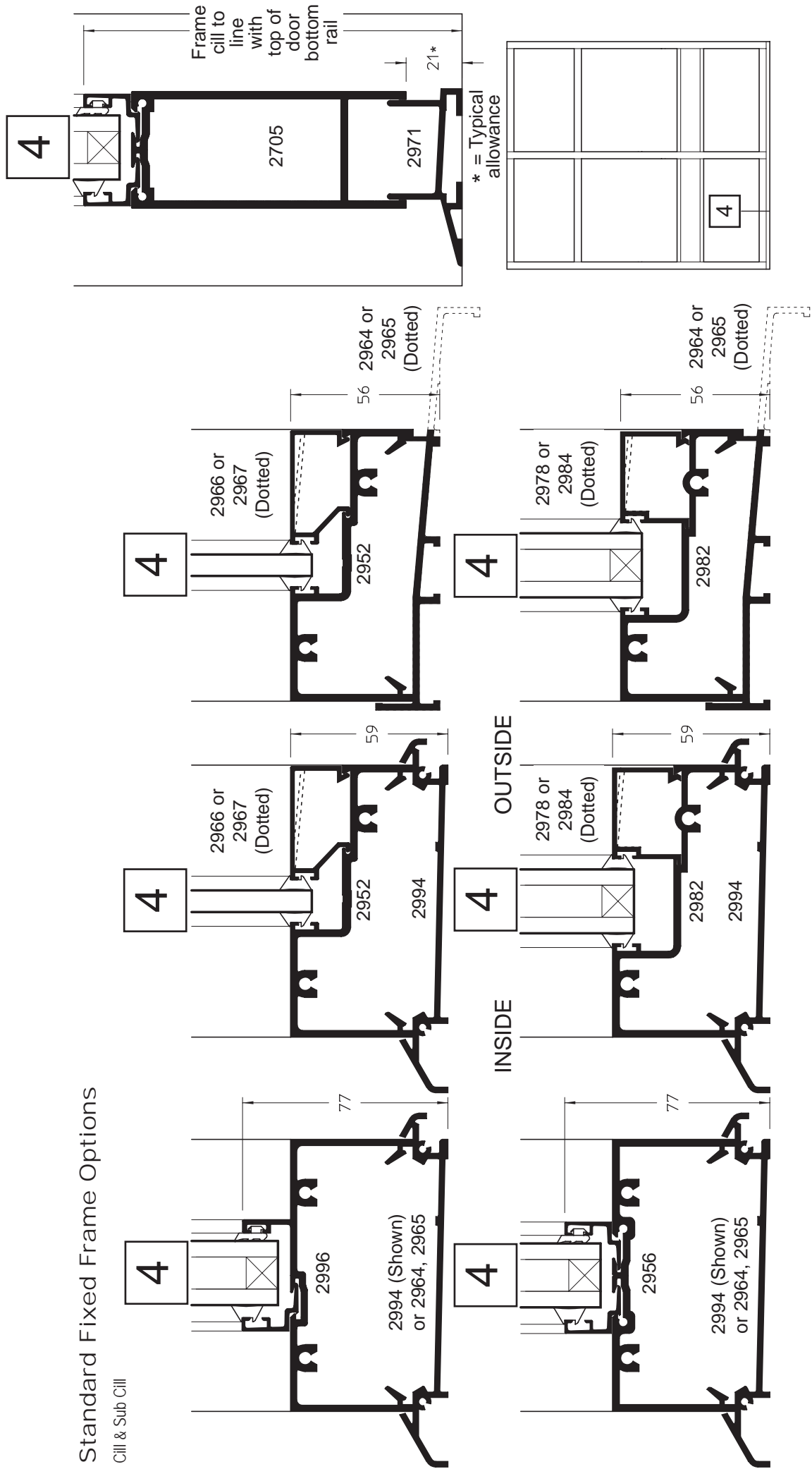

202 Non-thermally Broken Commercial Entrance Door & Framing

GENERAL ARRANGEMENTS

Standard Fixed Frame Options

Cill & Sub Cill

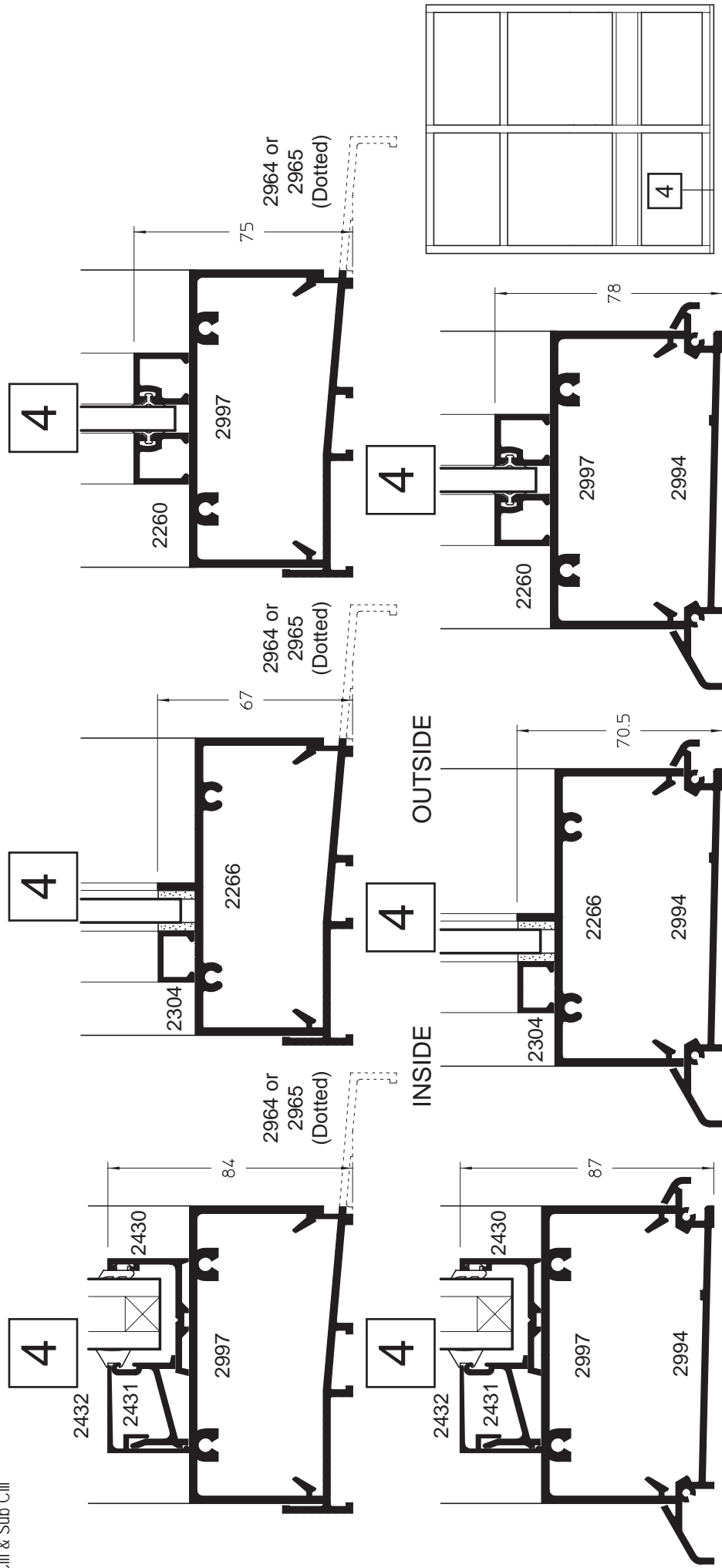

GENERAL ARRANGEMENTS

Standard Fixed Frame Options

Jamb

* = opposite hand to that shown

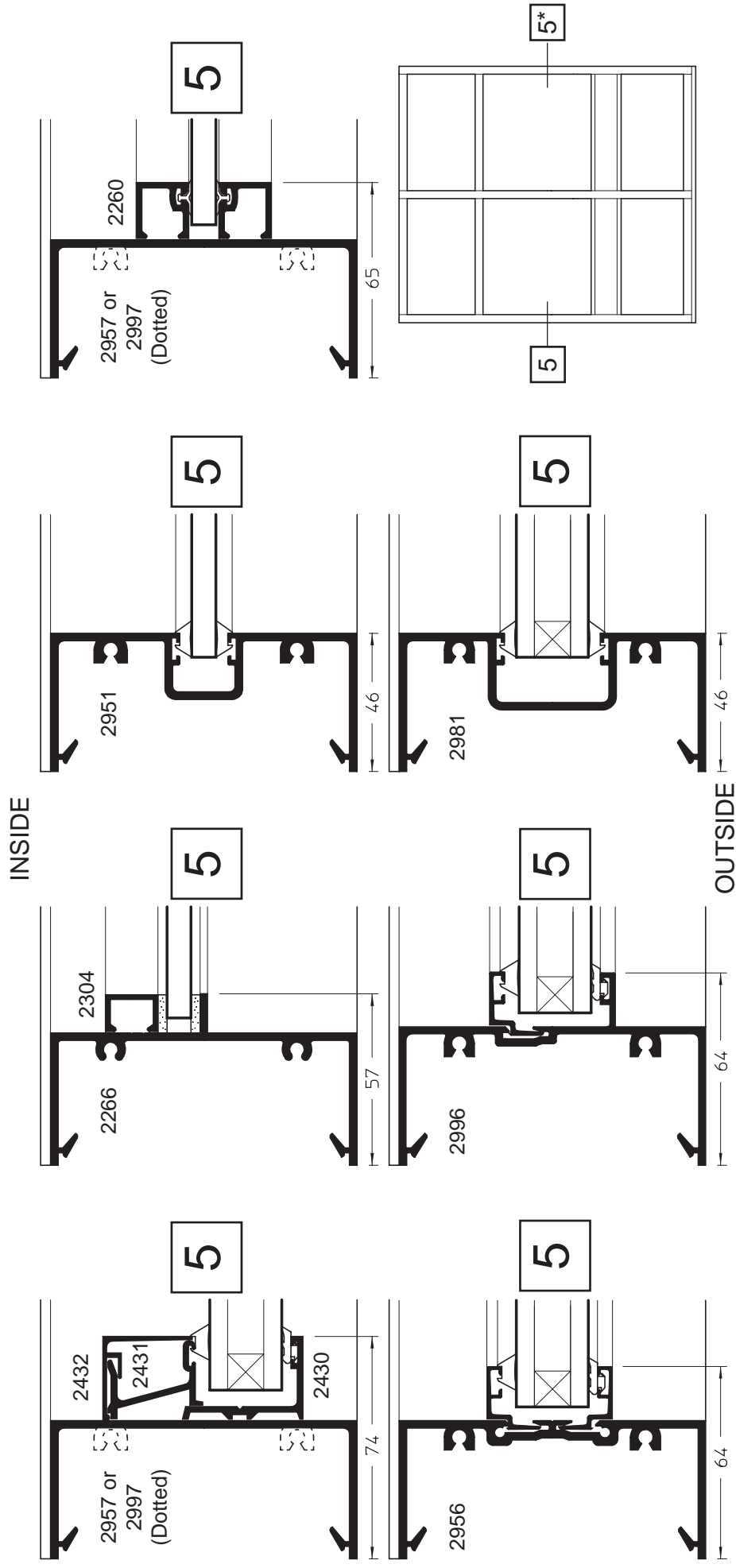

202 Non-thermally Broken Commercial Entrance Door & Framing

GENERAL ARRANGEMENTS

Standard Fixed Frame Options

Mullion

INSIDE

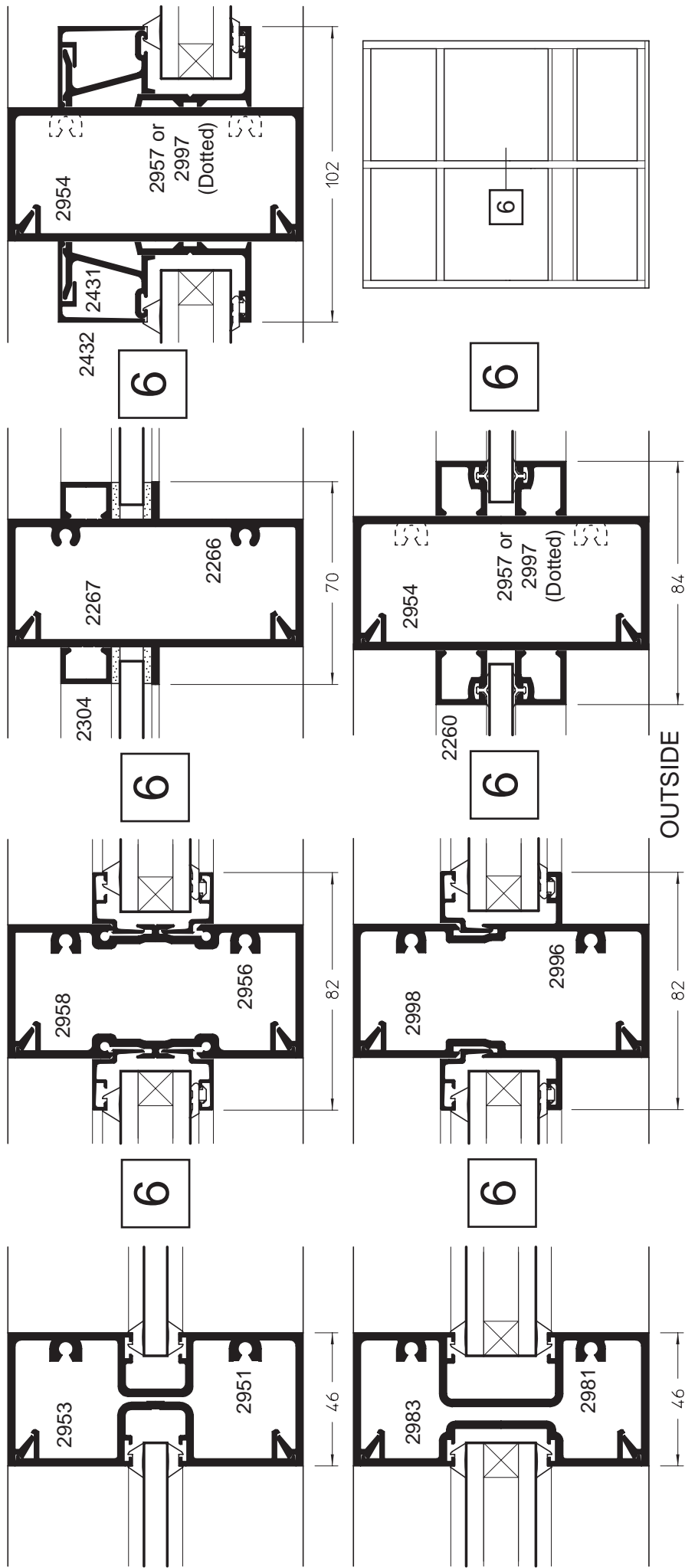

202 Non-thermally Broken Commercial Entrance Door & Framing

GENERAL ARRANGEMENTS

Standard Fixed Frame Options

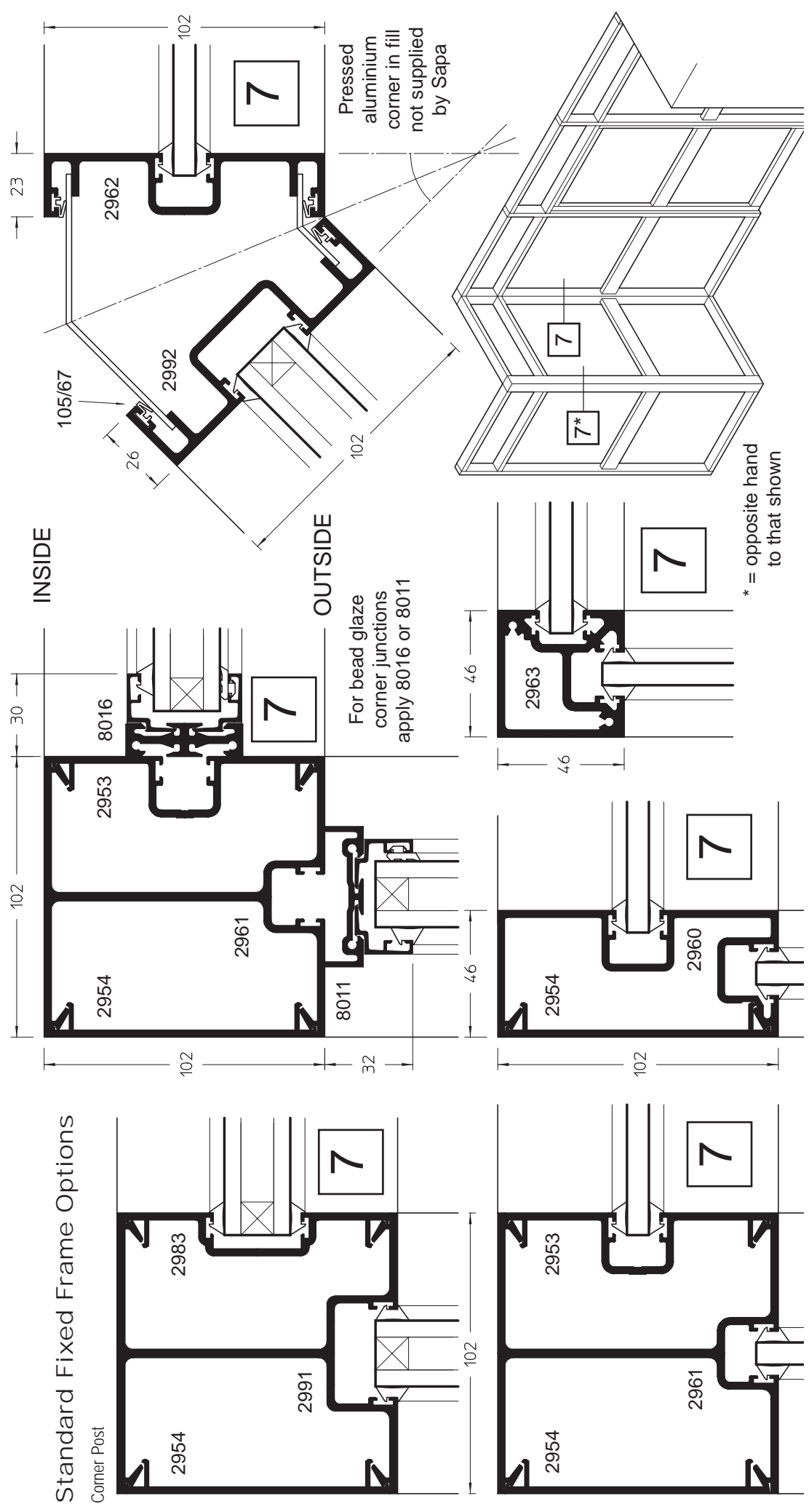

202 Non-thermally Broken Commercial Entrance Door & Framing

GENERAL ARRANGEMENTS

Standard Fixed Frame Options

75mm Framing

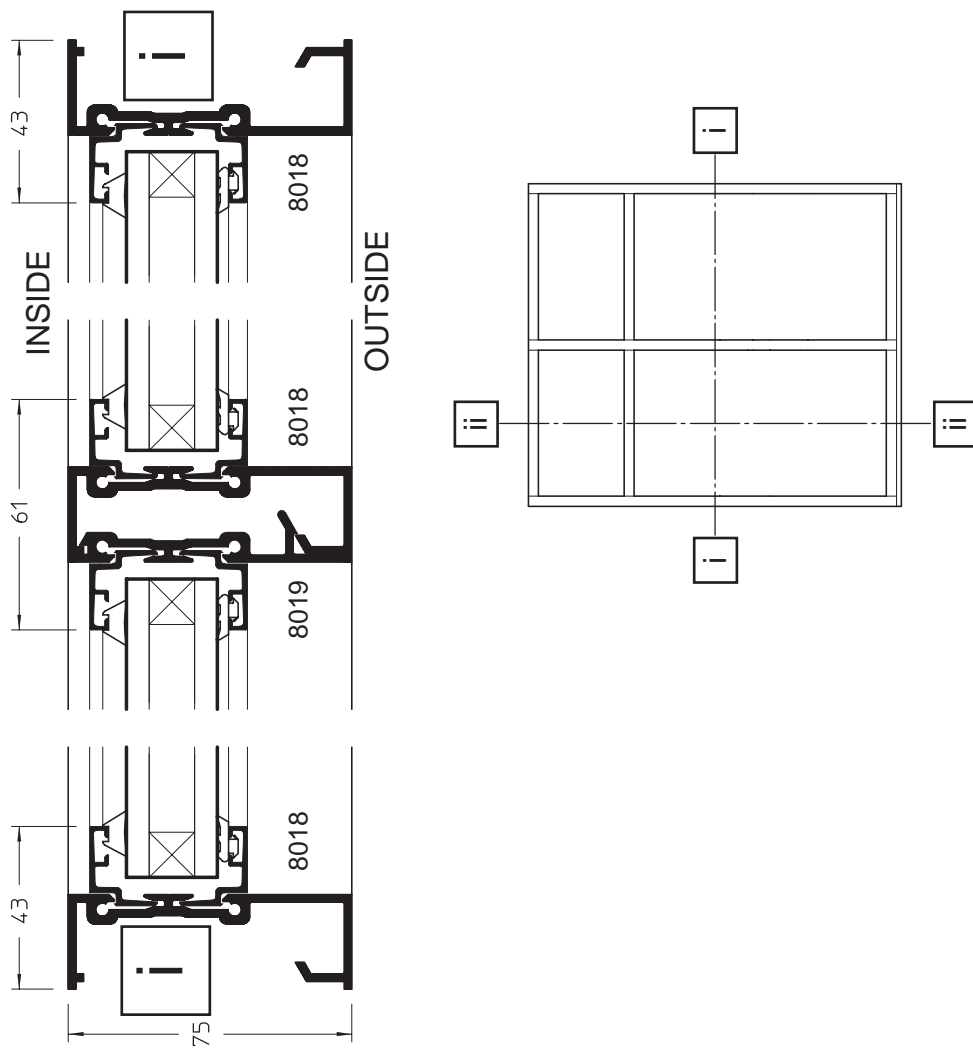
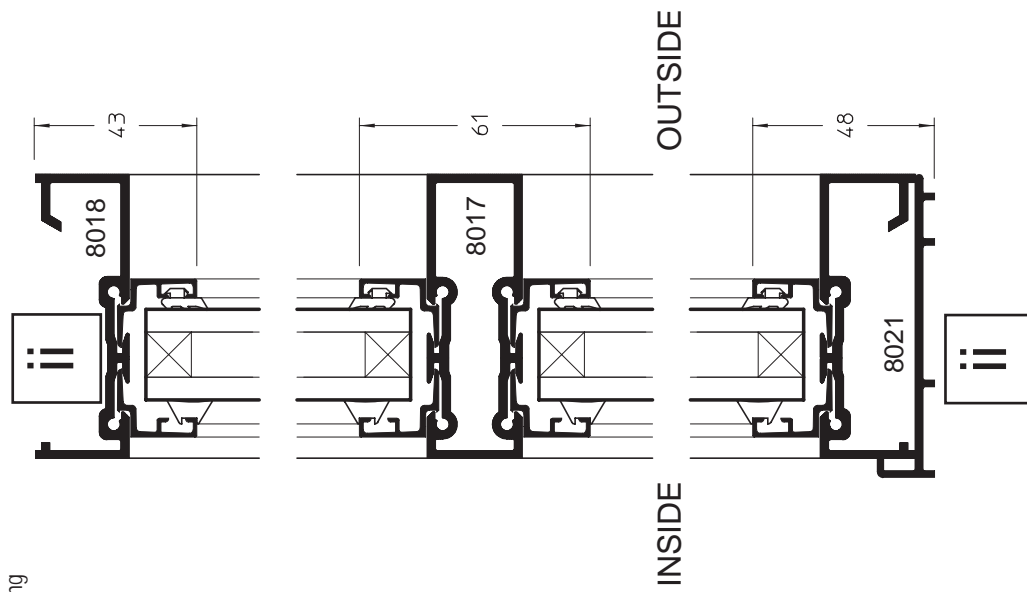

This page has been left intentionally blank

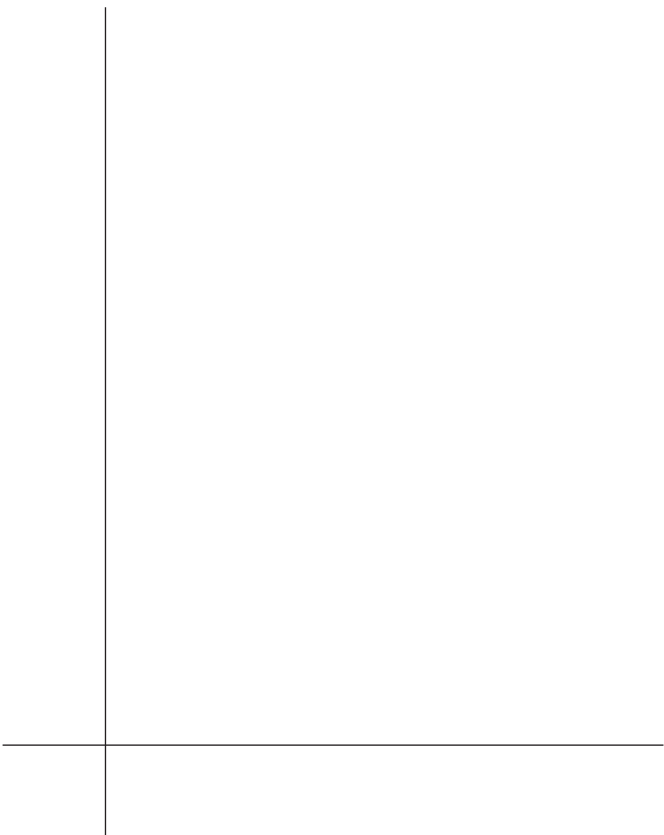

This page has been left intentionally blank

This page has been left intentionally blank

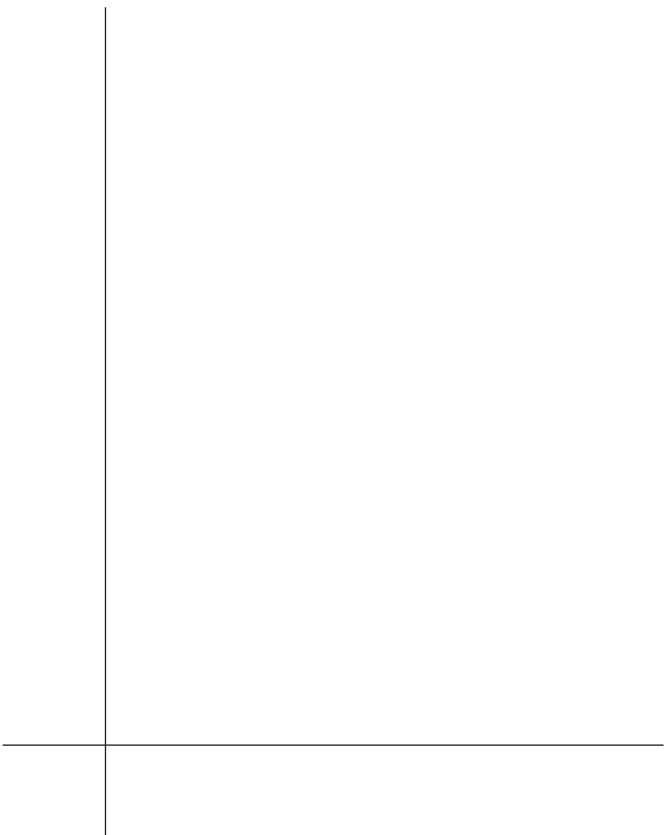

Our policy is one of continuous development and consequently we reserve the right to vary the products and their performance specification shown in this literature without notice.

All products and systems which Sapa supply are supplied subject to Sapa's standard Terms and Conditions of Sale which may vary from time to time.

This Technical Data Sheet is for specification guidance only. It should not be relied on for manufacturing or installation details which must instead be obtained from Sapa Building Systems' Fabrication Manuals. For further assistance please contact one of our Project Consultants by calling the Marketing Department on the number below.

© Sapa Building Systems Limited. This data sheet is issued subject to the condition that it shall not be reproduced without the consent of Sapa Building Systems Limited in writing

Brochure reference STC96 1207

Sapa Building Systems Limited

Postal address **Alexandra Way, Ashchurch, Tewkesbury, Gloucestershire GL20 8NB**
Telephone **01684 853500** Fax **01684 851850**
E-mail **info@sapabuildingsystems.co.uk** Website **www.sapabuildingsystems.co.uk**

